



# Operation & Service Manual

**MODELS:**

*DLT 8C (regular + Hydraulic)*

**REVISION 4/2025/AO**

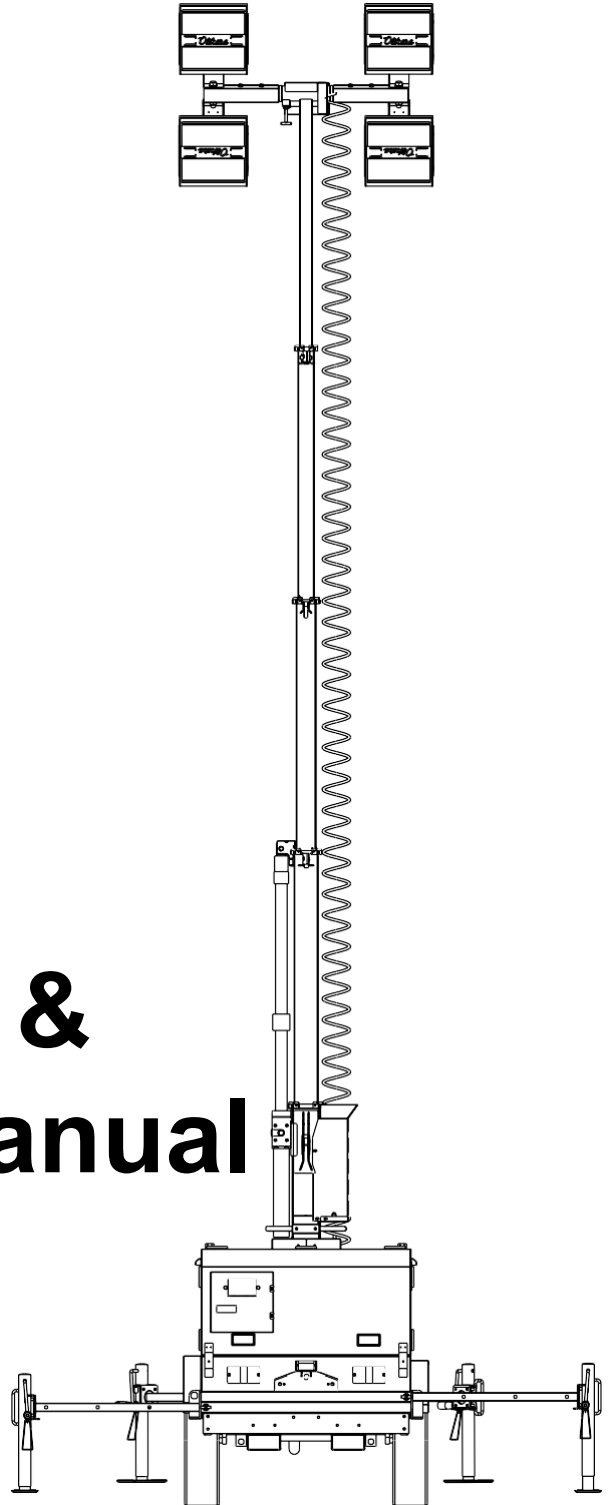

## FOREWORD

This manual contains important information about the light towers and specific instructions for its operation and maintenance. It is important to keep a copy of this manual in the machine “Operator manual” holder to ensure that all machine operators have quick access to this manual .

It is the responsibility of the owner/operator to perform the required maintenance, service and replacement of required parts / filters to ensure proper care of the machine and a safe work environment. It is also important to have an authorised service dealer inspect the machine on a periodic basis.

## CALIFORNIA PROPOSITION 65 WARNING



**Engine exhaust and some of its constituents are known to the state of California to cause cancer, birth defects, and other reproductive harm.**



This product contains or emits chemicals known to the state of California to cause cancer, birth defects, and other reproductive harm.



Always recycle batteries, battery posts, or any items containing lead or lead compounds at an official recycling center in accordance with all local laws and regulations. Failure to do so could result in environmental damage, death or serious injury.



To read more on Cancer and Reproductive harm please visit:  
[www.P65Warnings.ca.gov](http://www.P65Warnings.ca.gov)

# IMPORTANT INFORMATION ABOUT THIS MACHINE

Use this page to record information about your machine. The serial plate located on the machine will have the required data to fill this table up. Please see below for location of the serial plate.

<b>LIGHT TOWER MODEL</b>	
<b>LIGHT TOWER SERIAL NUMBER</b>	
<b>LIGHT TOWER MANUFACTURE CODE</b>	
<b>LED CONFIGURATION / WATTAGE</b>	
<b>ENGINE MODEL **</b>	
<b>ENGINE SERIAL NUMBER **</b>	
<b>ALTERNATOR MODEL **</b>	
<b>ALTERNATOR SERIAL NUMBER **</b>	

**\*\* Use the stickers on the engine and alternator to get the model and serial number details.**

## LOCATION OF THE SERIAL PLATE

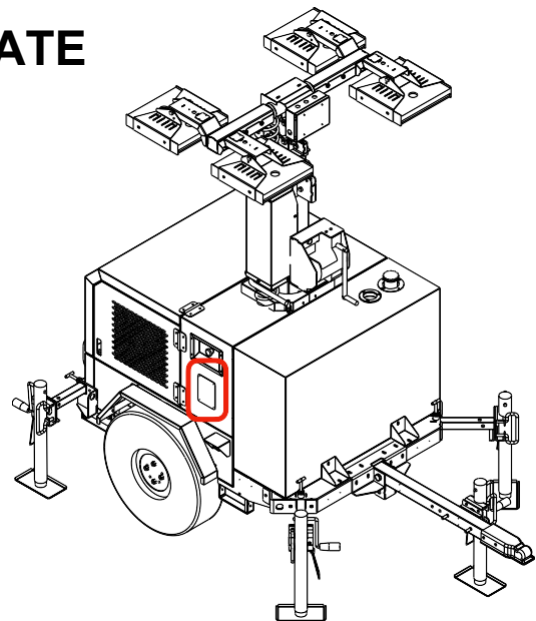

# INDEX

1. GENERAL INFORMATION	1
2. SAFETY INFORMATION	2
3. MACHINE DIMENSIONS	4
4. MACHINE PARTS	5
4.1 Component location	5
4.2 Component labels	6
4.3 Outlet / Inlet socket panel options	7
4.4 Controller details	8
4.5 Controller Fault alarm list	9
5. TOWING AND LIFTING	10
5.1 Towing the machine (Unhitching)	10
5.2 Towing the machine (Hitching)	11
5.3 Lifting the machine using central lifting eye	12
5.4 Lifting the machine using forklift pockets	13
5.5 Folding the towbar for storage (when available)	14
6. MACHINE SETUP	15
6.1 Checking and filling fluids in the machine	15
6.2 Lamp and lamp cross arm setup	16
6.3 Machine levelling	17
6.4 Hydraulic mast setup for use (where available)	18
7. MACHINE STARTUP / SHUTDOWN	19
7.1 Startup in Genset Power Mode	19
7.2 Cold Start in Genset Power Mode (If available)	20
7.3 Startup in Outside Power Mode (If available)	21

7.4 Startup/Shutdown using Dusk to Dawn sensor (If available)	22
7.5 Machine Shutdown process	23
7.6 Raising and lowering hydraulic mast (If provided)	24
<b>8. POWER OUTLET SOCKETS / RECEPTACLES</b>	<b>25</b>
8.1 Procedure to use Power Outlets / Receptacles	25
8.2 Derating information for genset power	26
<b>9. GENERAL MAINTENANCE</b>	<b>27</b>
9.1 Overall machine maintenance	27
9.1.1 Checklist to prep for machine maintenance	27
9.1.2 Maintenance schedule for proper machine use	27
9.2 Engine maintenance	28
9.2.1 Mitsubishi L2E & L3E engine	28
9.2.2 Maintenance Alarms on Controller	29
9.2.3 Oil, coolant and diesel details	29
9.2.4 Filter change process	30
9.2.5 Draining oil, coolant and bund trays	31
9.3 Hydraulic Mast maintenance	32
<b>10. TROUBLESHOOTING</b>	<b>33</b>
<b>11. NOTES</b>	<b>37</b>

# 1. GENERAL INFORMATION

The owner / operator is responsible for proper maintenance and safe operation of the equipment. It is important to comply with all the required and appropriate regulations of the Safety and Health Administration or equivalent local health and safety rules and standards. Ensure that the machine is commissioned, used and maintained according to the manufacturer’s instructions and recommendations.

**⚠ DO NOT ALTER OR MODIFY THE MACHINE IN A WAY THAT MAY MAKE THE LIGHT TOWER IN NON-COMPLIANCE WITH THE FEDERAL AND LOCAL SAFETY CODES, STANDARDS, LAWS OR REGULATIONS.**

The manufacturer cannot anticipate all possible situations that might involve unsafe conditions, or potential hazards to people and equipment. As a result all the warnings, labels, cautions that are listed in the manual and on decals on the machine represent only a portion of all risks involved in running or using the equipment. Accordingly it is very important that if something looks unsafe, or looks dangerous for the operator or for others around, turn off the machine and/ or move everyone to a safe location.

Decals on the machine with the following instructions will mean the following:

<b>DANGER</b>	<i>This is a hazardous and dangerous situation which if not handled properly or avoided will result in death/serious injury or serious damage to property</i>
<b>WARNING</b>	<i>This is a hazardous and dangerous situation which if not handled properly or avoided could result in death/serious injury or serious damage to property</i>
<b>CAUTION</b>	<i>This is a hazardous and dangerous situation which if not handled properly or avoided could result in minor or moderate injury or minor/moderate damage to property</i>

The portable light tower is built for large scale illumination of outdoor areas and providing auxiliary power to connected loads like small tools or additional lighting. It should be operated on and maintained by persons who are trained on the use and maintenance of this particular model(s) of light towers and are older than 18 years of age. No one who is impaired by alcohol, drugs or prescription medication should operate or be next to the machine when it is setup or operational.

## 2. SAFETY INFORMATION

- ☑ DO NOT run the machine in “Genset power” mode in closed areas. The Diesel engines produce carbon monoxide which is a colourless, odourless and poisonous gas. Breathing it in will cause unconsciousness or even death.
- ☑ DO NOT run the engine with the hood open and without adequate hearing protection. It could lead to hearing loss if exposed to the sound for long durations.
- ☑ DO NOT wear loose clothes or keep long hair open when working on an operating engine.
- ☑ Always wear appropriate PPE when working on the light tower. There are a number of surfaces that are very HOT during operation and could cause burns when touched without gloves.
- ☑ Always ensure that there is sufficient ventilation and air flow around the machine to reduce fire or explosion risks.
- ☑ DO NOT put any combustible material like clothes, paper etc on or under the engine inside the machine as that might catch fire.
- ☑ DO NOT put petrol or any other alternative fuels into the tank. Only fill LOW SULPHUR diesel.
- ☑ Always wipe excess oil or diesel that might splash on the soundproof foam. Failure to do so might cause fires.
- ☑ DO NOT fill the fuel tank while the engine is running.
- ☑ DO NOT loosen any hydraulic fittings without de-pressurising the hydraulic system first. Failure to do so might cause serious injuries.
- ☑ DO NOT operate on any electrical items or wiring in/on the light tower without first shutting all power sources off. This unit generates high voltage and current that can cause serious injury or even death.
- ☑ Always make sure that the machine is properly grounded.
- ☑ DO NOT plug any cords or cables that are worn out or have their insulation cut with the bare copper exposed.
- ☑ DO NOT operate or perform electrical repairs on the machine when standing in water.
- ☑ Always take precaution when working on batteries. They emit explosive gases when charging.
- ☑ DO NOT throw old batteries into trash cans as they can leak poisonous liquids.

## 2. SAFETY INFORMATION

- ☑ DO not operate or raise the light tower under high voltage lines or trees or obstructions. Contact with the obstructions could cause injury to the operator or damage to the tower.
- ☑ DO NOT start or operate a machine that is damaged or in need for maintenance.
- ☑ DO NOT run the machine in severe weather or in thunder/lightning storms. Lightning strikes can cause severe injury or death to people around the tower.
- ☑ Always bring the mast down in high winds (> 80 mph). High winds can cause the machine to topple over.
- ☑ DO not raise the mast or lower it if any of the tubes get stuck or the wire rope becomes slack. Immediately call service support.
- ☑ Always extend the outriggers and level the light tower before operating or raising the mast.
- ☑ Always make sure that all the stabilizer jacks are resting on firm hard ground. If that is not possible make sure that large firm plates are placed under the jack to ensure proper ground support.
- ☑ Always connect the trailer chains to the tow vehicle by crossing over underneath the towbar.
- ☑ Make sure that the hitch and coupling on the towing vehicle are rated equal to or greater than the Gross Vehicle Weight Rating (GVWR).
- ☑ Make sure the brake lights and indicators are working properly after connecting the tow connector
- ☑ Make sure that the pneumatic tires are properly filled with air to the correct pressure.
- ☑ Make sure that the wheel lugs are present and tightened to the specified torque.

### 3. MACHINE DIMENSIONS

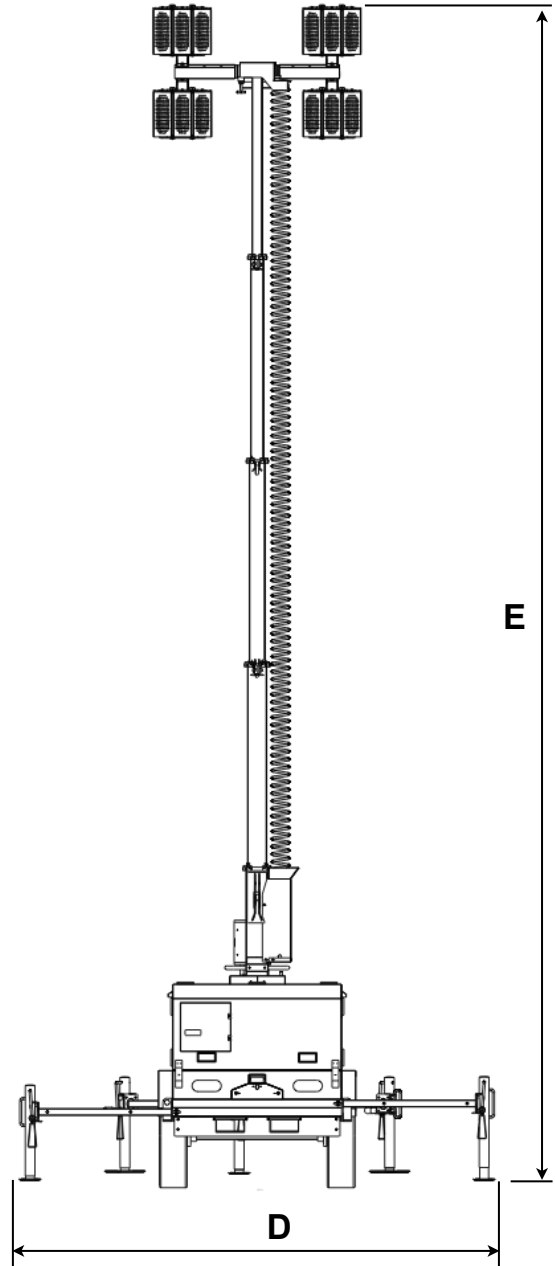
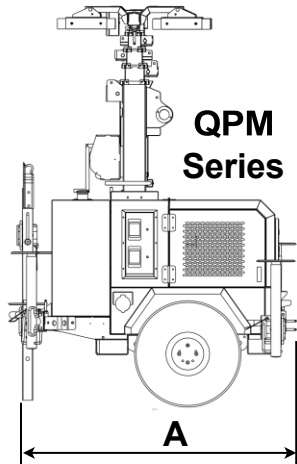
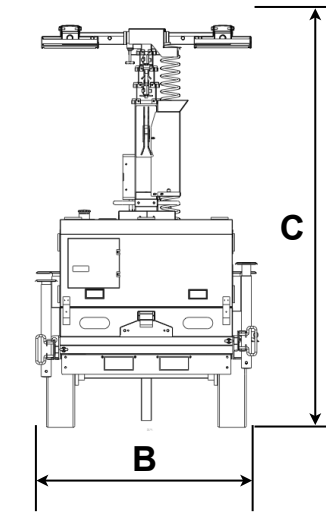

MODEL	A (folded)	A (unfolded)	B	C	D	E
<b>X-DLT-4XX</b>	1.56 m (61.4 in)	2.46 m (61.4 in)	1.2 m (47 in)	2.3 m (91 in)	2.7 m (108 in)	7 m (23 ft)
<b>X-DLT-8XX</b>	1.56 m (61.4 in)	2.46 m (61.4 in)	1.44 m (56.5 in)	2.3 m (91 in)	2.7 m (108 in)	7 m (23 ft)

# 4. MACHINE PARTS

## 4.1 Component location

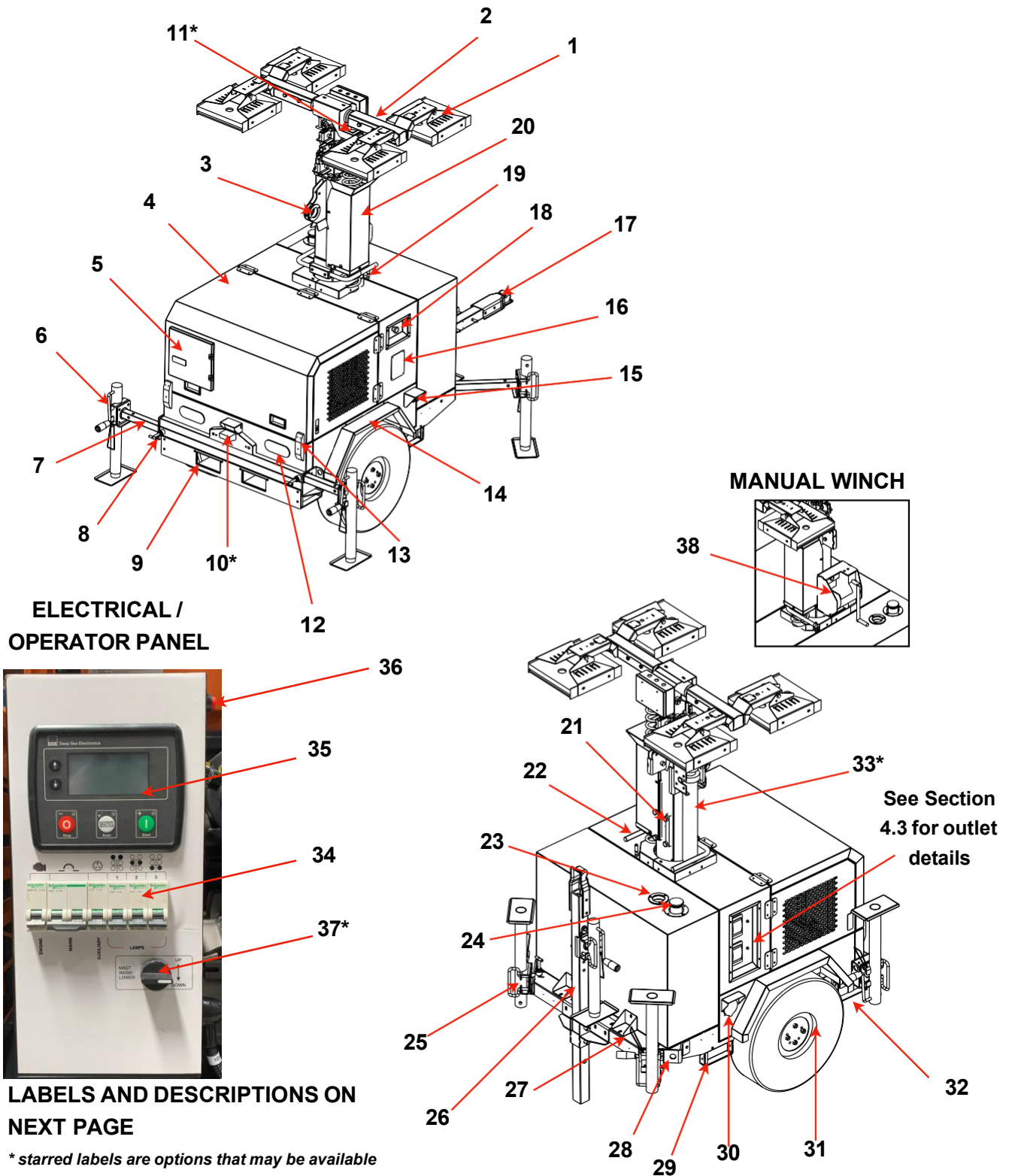

**ELECTRICAL / OPERATOR PANEL**

**LABELS AND DESCRIPTIONS ON NEXT PAGE**

*\* starred labels are options that may be available based on spec chosen.*

## 4. MACHINE PARTS

### 4.2 Component labels

<b>1</b>	LED lamp 350W	<b>23</b>	Fuel gauge port window
<b>2</b>	Light cross arm	<b>24</b>	Fuel tank inlet with cap
<b>3</b>	Central lifting eye/ hook	<b>25</b>	Stabilizer jack (front)
<b>4</b>	Canopy hood	<b>26</b>	Drawbar / tongue
<b>5</b>	Canopy operator door	<b>27</b>	Footstep
<b>6</b>	Stabilizer jack (rear)	<b>28</b>	Front tie down eye
<b>7</b>	Outrigger tube	<b>29</b>	Side forklift pocket (front)
<b>8</b>	Outrigger locking pin	<b>30</b>	Inlet power socket (shore socket)
<b>9</b>	Rear forklift pocket	<b>31</b>	13" pneumatic tire
<b>10</b>	License plate light	<b>32</b>	Side forklift pocket (rear)
<b>11</b>	Dawn to Dusk (D2D) sensor with cover	<b>33</b>	Hydraulic cylinder (Available on hydraulic machines)
<b>12</b>	Taillight / brake light	<b>34</b>	MCBs for engine, mains and lamps
<b>13</b>	Canopy hood lock	<b>35</b>	DEEPSEA genset controller
<b>14</b>	Mudguard	<b>36</b>	Fuel pump over-ride button
<b>15</b>	Engine exhaust tail pipe	<b>37</b>	Hydraulic mast raise/lower switch (Available in machines with hydraulic mast option)
<b>16</b>	Serial plate	<b>38</b>	Manual Winch
<b>17</b>	2" ball hitch coupler		
<b>18</b>	Emergency stop + battery isolator		
<b>19</b>	Mast rotation lock		
<b>20</b>	Coil wire collection tube		
<b>21</b>	Telescopic mast		
<b>22</b>	Mast rotation handle		

## 4. MACHINE PARTS

### 4.3 Outlet / Inlet socket panel options

SOCKET TRAY #1

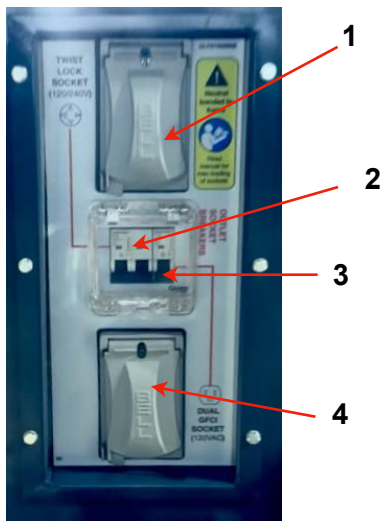

SOCKET TRAY #2







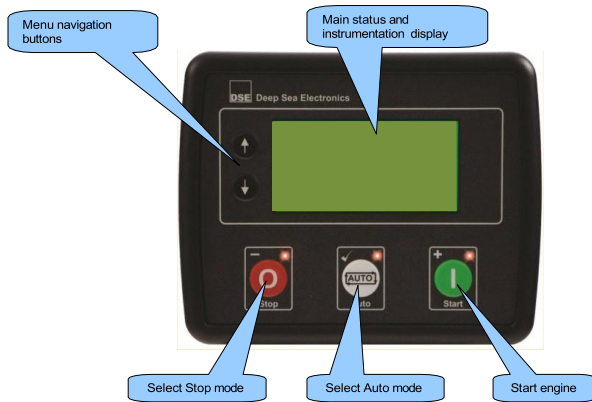

1	Twist lock socket, 4 pin, 240VAC
2	2 pole breaker for Twist lock
3	Duplex socket, 3 pin, 20A, 120VAC
4	1 pole breaker for duplex socket

## 4. MACHINE PARTS

### 4.4 Controller details

The controller that is used in both models is a DEEPSEA 4520 controller.

























<p><b>Stop / Reset</b> This button places the module into its <b>Stop/Reset</b>  mode. will clear any alarm conditions for which the triggering criteria have been removed. If the engine is running and the module is in Stop mode, the module will automatically instruct the changeover device to unload the generator (<b>'Close Generator' becomes inactive (if used)</b>). The fuel supply de-energises and the engine comes to a standstill. Should a <b>remote start signal</b> be present while operating in this mode, a remote start will <u>not</u> occur.</p>	
<p><b>Auto</b> This button places the module into its <b>'Automatic'</b> mode. This mode allows the module to control the function of the generator automatically. The module will monitor the <i>remote start</i> input and mains supply status and once a start request is made, the set will be automatically started and placed on load. Upon removal of the starting signal, the module will automatically transfer the load from the generator and shut the set down observing the <i>stop delay</i> timer and <i>cooling</i> timer as necessary. The module will then await the next start event. <i>For further details, please see the more detailed description of 'Auto operation' elsewhere in this manual.</i></p>	
<p><b>Start</b> This button is only active in STOP/RESET mode. Pressing this button in manual or test mode will start the engine and run off load (manual) or on load (test). Pressing this button in STOP/RESET  mode will turn on the CAN engine ECU (when correctly configured and fitted to a compatible engine ECU)</p>	
<p><b>▲NOTE: Different modes of operation are possible - Please refer to your configuration source for details.</b></p>	
<p><b>Menu navigation</b> Used for navigating the instrumentation, event log and configuration screens. For further details, please see the more detailed description of these items elsewhere in this manual.</p>	

## 4. MACHINE PARTS

### 4.5 Controller Fault alarm list

Below is a list of all the faults that correspond to the fault symbols that are displayed on the controller:

ICON	DESCRIPTION	
	AUXILIARY INPUTS	Auxiliary inputs can be user configured and will display the message as written by the user.
	FAIL TO START	The engine has not fired after the preset number of start attempts
	FAIL TO STOP	The module has detected a condition that indicates that the engine is running when it has been instructed to stop. <b>NOTE:</b> 'Fail to Stop' could indicate a faulty oil pressure sensor - If engine is at rest check oil sensor wiring and configuration.
	LOW OIL PRESSURE	The module detects that the engine oil pressure has fallen below the low oil pressure pre-alarm setting level after the Safety On timer has expired.
	ENGINE HIGH TEMPERATURE	The module detects that the engine coolant temperature has exceeded the high engine temperature pre-alarm setting level after the Safety On timer has expired.
	UNDERSPEED	The engine speed has fallen below the underspeed pre alarm setting
	OVERSPEED	The engine speed has risen above the overspeed pre alarm setting
	CHARGE FAILURE	The auxiliary charge alternator voltage is low as measured from the W/L terminal.
	LOW FUEL LEVEL	The level detected by the fuel level sensor is below the low fuel level setting.
	BATTERY UNDER VOLTAGE / BATTERY OVER VOLTAGE	The DC supply has fallen below or risen above the low/high volts setting level.
	GENERATOR UNDER VOLTAGE	The generator output voltage has fallen below the pre-set pre-alarm setting after the Safety On timer has expired.
	GENERATOR OVER VOLTAGE	The generator output voltage has risen above the pre-set pre-alarm setting.
	GENERATOR UNDER FREQUENCY	The generator output frequency has fallen below the pre-set pre-alarm setting after the Safety On timer has expired.
	GENERATOR OVER FREQUENCY	The generator output frequency has risen above the pre-set pre-alarm setting.
	CAN ECU WARNING CAN ECU SHUTDOWN	The engine ECU has detected an alarm – CHECK ENGINE LIGHT Contact Engine Manufacturer for support.
	CAN DATA FAIL	The module is configured for CAN operation and does not detect data on the engine Can data link.
	EMERGENCY STOP	The emergency stop button has been depressed. This failsafe (normally closed to emergency stop) input and will immediately stop the set should the signal be removed.
	OIL SENDER OPEN CIRCUIT	Oil pressure sensor has been detected as being open circuit.
	FLEXIBLE SENSOR	The flexible sensor shutdown alarm has been triggered.
	OVERCURRENT	The current has risen above the set limit trip.
	OIL FILTER MAINTENANCE ALARM	Maintenance due for oil filter.
	AIR FILTER MAINTENANCE ALARM	Maintenance due for air filter
	FUEL FILTER MAINTENANCE ALARM	Maintenance due for fuel filter.

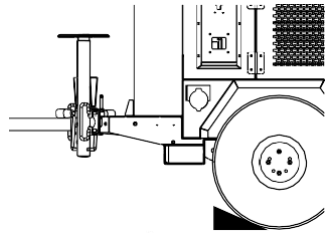
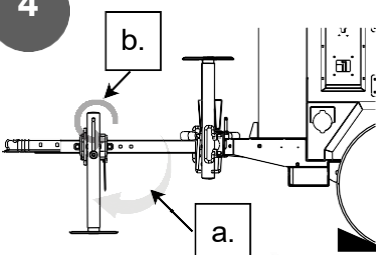
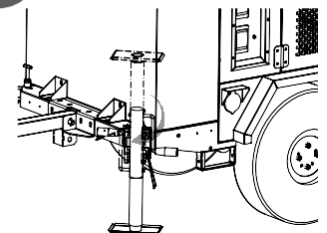
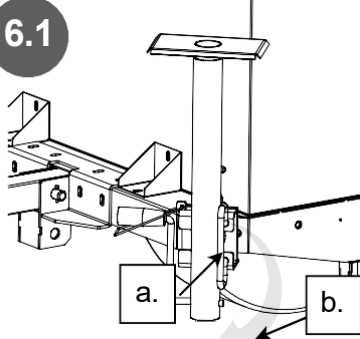
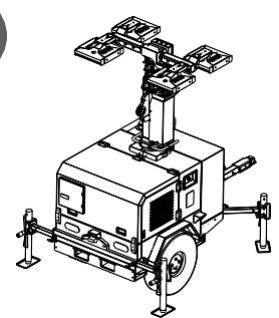

## 5. TOWING AND LIFTING

### 5.1 Towing the machine (Unhitching)

<p><b>1</b></p> <p><b>WARNINGS</b></p> <ul style="list-style-type: none"> <li>⚠ Machine parked on level surface</li> <li>⚠ No overhead obstructions</li> <li>⚠ Machine is parked on firm surface and not loose mud</li> <li>⚠ Machine is not parked in standing water</li> <li>⚠ There is clear space of 10 feet around the machine</li> </ul>	<p><b>2</b></p>  <p>Chock the wheels / pull handbrake if available.</p>	<p><b>3</b></p> <ul style="list-style-type: none"> <li>a. Disconnect the chains and tow plug (if available).</li> <li>b. Release the ball hitch coupler lock / remove the tow pin.</li> </ul>
<p><b>4</b></p>  <ul style="list-style-type: none"> <li>a. Unhitch from towing vehicle by rotating the drawbar/tongue jack down.</li> <li>b. Extend jack by turning the handle CCW.</li> </ul>	<p><b>5</b></p> <ul style="list-style-type: none"> <li>a. Once the tow hitch coupler is clear of the tow vehicle, carefully drive the tow vehicle clear of the machine.</li> </ul>	<p><b>6</b></p>  <ul style="list-style-type: none"> <li>a. Pull jack rotation lock and rotate the 4 other jacks to operational orientation.</li> <li>b. Follow block #6.1 on how to rotate the jack</li> </ul>
<p><b>6.1</b></p>  <ul style="list-style-type: none"> <li>a. Pull the rotation handle out.</li> <li>b. While pulled out, rotate the entire jack</li> </ul>	<p><b>7</b></p>  <ul style="list-style-type: none"> <li>a. Final setup of machine should look like above picture.</li> </ul>	<p><b>INTENTIONALLY LEFT BLANK</b></p>

## 5. TOWING AND LIFTING

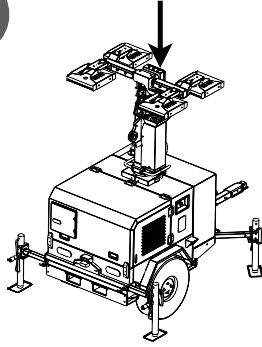
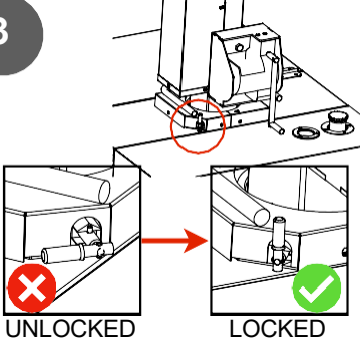
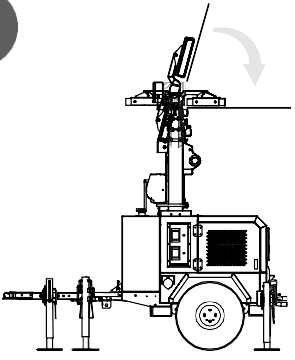
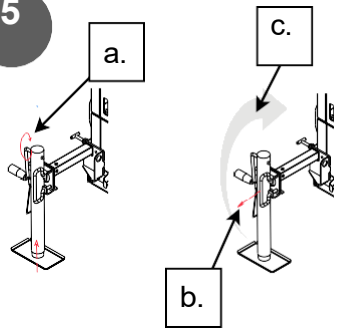
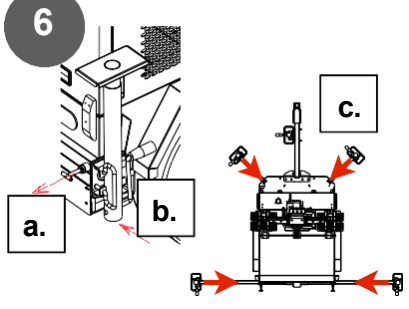
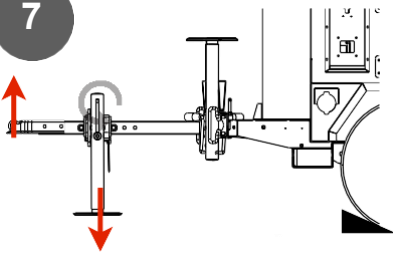
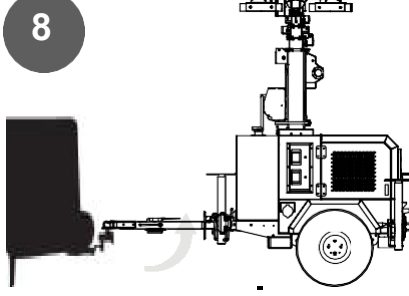
### 5.2 Towing the machine (Hitching)

<p><b>1</b></p> <p><b>WARNINGS</b></p> <ul style="list-style-type: none"> <li>⚠ Machine parked on level surface</li> <li>⚠ Wheels are chocked</li> <li>⚠ Machine is parked on firm surface and not loose mud</li> <li>⚠ Machine is not parked in standing water</li> <li>⚠ There is clear space for the tow vehicle to approach and couple with the machine</li> </ul>	<p><b>2</b></p>  <p>a. Using the winch, make sure the mast is completely retracted</p>	<p><b>3</b></p>  <p>a. Make sure the mast rotation lock is in the locked position and the mast is secure.</p>
<p><b>4</b></p>  <p>a. Tilt light arm to travel position</p>	<p><b>5</b></p>  <p>a. Rotate handle retract the jacks b. Pull handle c. Rotate jacks into travel position</p>	<p><b>6</b></p>  <p>a. Pull spring handle b. Push jack &amp; outrigger into machine c. Do same for all 4 side jacks/outriggers</p>
<p><b>7</b></p>  <p>a. Raise coupler to allow tow vehicle to be positioned underneath. b. Apply thin film of grease on coupler. c. Lower jack to couple.</p>	<p><b>8</b></p>  <p>a. After coupling, retract and rotate the drawbar jack by 90 deg.</p>	<p><b>9</b></p>  <p>a. Unchock the wheels. b. Plug the trailer plug (if available). c. Connect the safety chains (if available). Ensure that it is crossed over when connecting to the tow vehicle.</p>





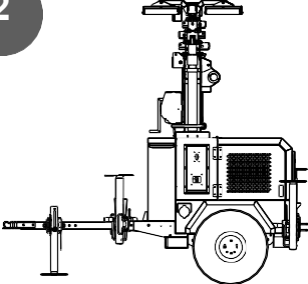
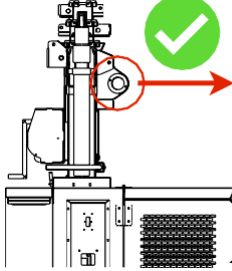
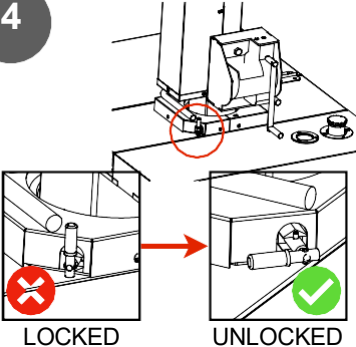
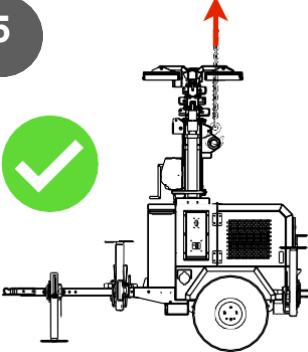
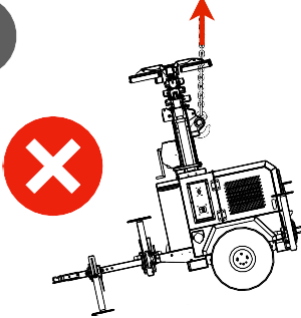
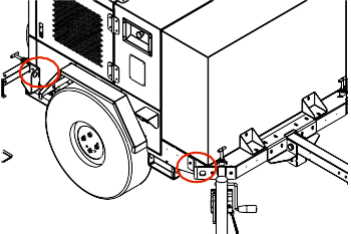

## 5. TOWING AND LIFTING

### 5.3 Lifting the machine using central lifting eye

<p><b>1</b></p> <p><b>WARNINGS</b></p> <ul style="list-style-type: none"> <li>⚠ Lifting crane should be on a firm surface</li> <li>⚠ Atleast 1 stabiliser jack should be oriented with the plate facing the ground.</li> <li>⚠ Lifting eye should face the rear direction of the machine (hood side)</li> <li>⚠ Always check the tackles and hooks for load rating</li> </ul>	<p><b>2</b></p>  <p>a. Get machine into position shown above. It is also possible to lift with the tow bar folded. b. Follow blocks #2 - #6 in section 5.2 to setup the machine.</p>	<p><b>3</b></p>  <p>a. Make sure that the central lifting eye is facing the rear direction (hood side).</p> <p>⚠ <b>DO NOT LIFT THE MACHINE WITH THE EYE FACING IN ANY OTHER DIRECTION</b></p>
<p><b>4</b></p>  <p>LOCKED      UNLOCKED</p> <p>a. Release the mast rotation locking pin before lifting. Keep in the unlocked condition.</p>	<p><b>5</b></p>  <p>a. Connect the lifting equipment to the lifting eye using shackles, chain etc.</p>	<p><b>6</b></p>  <p>a. Lift the machine a little bit off the ground and check for stability. b. <b>DO NOT</b> lift if the machine is tilting excessively in one direction.</p>
<p><b>7</b></p> <p>a. Continue to lift the machine b. <b>HOLD THE DRAWBAR OR THE MACHINE TO PREVENT IT FROM TURNING WHILE LIFTING.</b> c. Position it and drop in location desired. d. Make sure that the final resting position is level and can take the weight of the machine.</p>	<p><b>8</b></p>  <p>a. Use the tie-down eyes to strap the machine down. b. There are 2 located on both sides of the machine as shown above</p>	<p><b>9</b></p> <p><b>INTENTIONALLY LEFT BLANK</b></p>

## 5. TOWING AND LIFTING

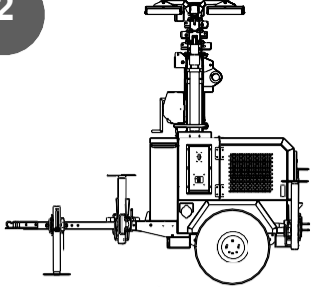
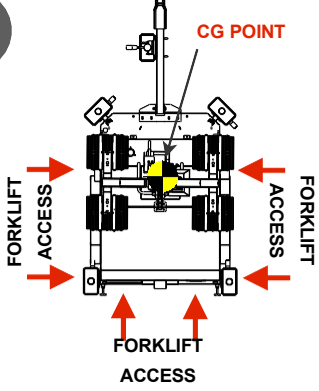
### 5.4 Lifting the machine using forklift pockets

<p><b>1</b></p> <p><b>WARNINGS</b></p> <ul style="list-style-type: none"> <li> Forklift operator should be trained / licensed.</li> <li> Forklift truck should be rated for the load of the machine.</li> <li> Always ensure the CG position of machine is within the end of the forks</li> <li> DO NOT work on inclined surfaces where there is a danger of tilting over</li> </ul>	<p><b>2</b></p>  <ol style="list-style-type: none"> <li>a. Get machine into position shown above. It is also possible to lift with the tow bar folded.</li> <li>b. Follow blocks #2 - #6 in section 5.2 to setup the machine.</li> </ol>	<p><b>3</b></p>  <ol style="list-style-type: none"> <li>a. Insert the forks into the pockets shown above</li> </ol>
<p><b>4</b></p> <ul style="list-style-type: none"> <li> <b>ALWAYS MAKE SURE THE FORKS EXTEND BEYOND THE CG POINT WHEN LIFTING FOR ADDED SAFETY.</b></li> <li> To access the side forklift pockets, please rotate the rear jacks by 90 deg or remove the outriggers with the jacks completely.</li> </ul>	<p><b>5</b></p> <ol style="list-style-type: none"> <li>a. Lift the machine a little bit off the ground and check for stability.</li> <li>b. DO NOT lift if the machine is tilting excessively in one direction.</li> </ol>	<p><b>6</b></p> <ol style="list-style-type: none"> <li>a. Continue to lift the machine and position in location desired.</li> <li>b. Make sure that the final resting position is level and can take the weight of the machine.</li> </ol>
<p><b>7</b></p> <p>INTENTIONALLY LEFT BLANK</p>	<p>INTENTIONALLY LEFT BLANK</p>	<p>INTENTIONALLY LEFT BLANK</p>

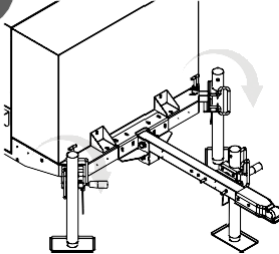
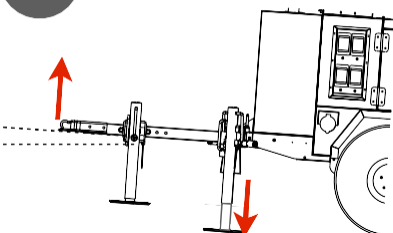
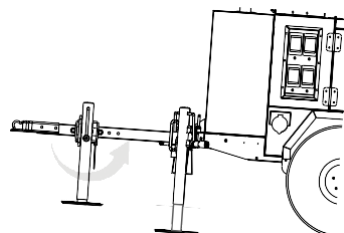
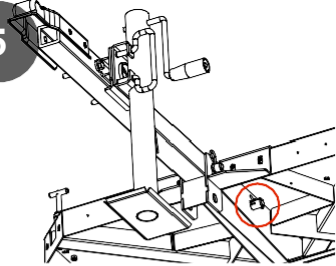
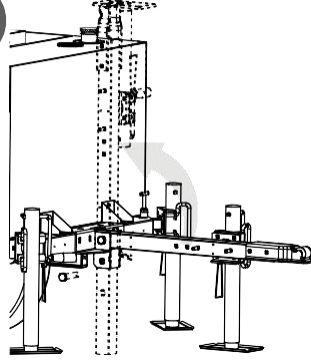
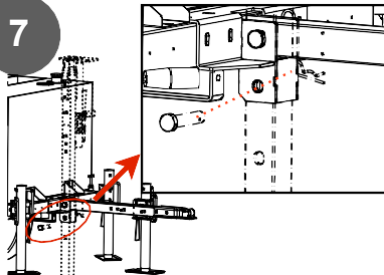
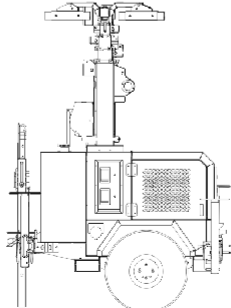

## 5. TOWING AND LIFTING

### 5.5 Folding the towbar for storage (when available)

<p><b>1</b> <b>CAUTION</b></p> <ul style="list-style-type: none"> <li>⚠ DO NOT operate the machine with the drawbar folded UP.</li> <li>⚠ DO NOT store the machine with the mast extended and the drawbar folded</li> <li>⚠ DO NOT attempt folding drawbar with the mast extended</li> <li>⚠ Always ensure that the side jacks are supporting the machine when folding the drawbar</li> </ul>	<p><b>2</b></p>  <p>a. Rotate the 2 jacks at the front (next to the fuel tank) to the operation position</p>	<p><b>3</b></p>  <p>a. Extend the rear jacks to lift the drawbar above the horizontal</p>
<p><b>4</b></p>  <p>a. Rotate the jack on the drawbar to the stow position</p>	<p><b>5</b></p>  <p>a. Reach underneath the trailer and pull out the 'R' pin from the towbar tilting locking pin b. Pull out the towbar tilting pin from the other side. Jiggle the tow bar is the pin feels stuck.</p>	<p><b>6</b></p>  <p>a. Carefully tilt the towbar to a vertical position.</p>
<p><b>7</b></p>  <p>a. Insert the locking pin into the circled hole to lock the drawbar in the vertical position b. Pass the 'R' pin into the locking pin to secure it.</p>	<p><b>8</b></p>  <p>a. Retract the two jacks until the machine is resting on the tow bar bottom. b. Rotate and position the jacks in the stow position.</p>	<p><b>9</b></p>

## 6. MACHINE SETUP

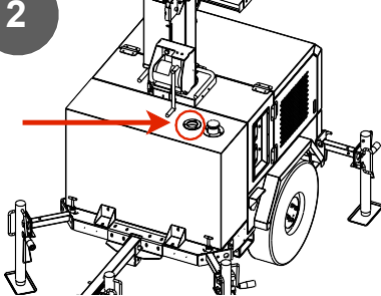
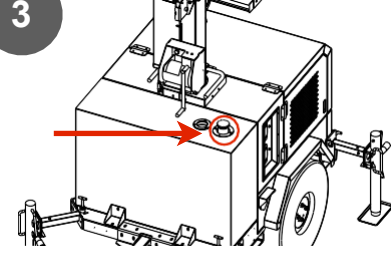
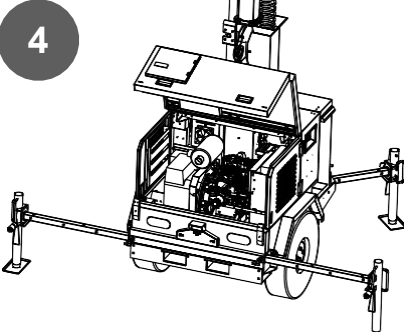
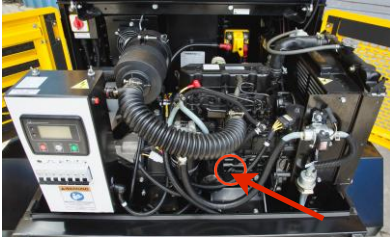
### 6.1 Checking and filling fluids in the machine

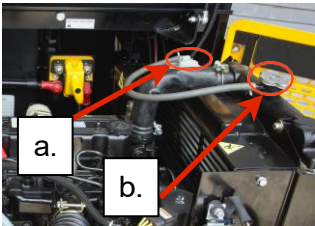
<p><b>1</b></p> <p><b>WARNINGS</b></p> <ul style="list-style-type: none"> <li>⚠ Diesel is dangerous. Use care when filling diesel. It can be explosive</li> <li>⚠ DO NOT spill or dispose oil or diesel on the ground.</li> <li>⚠ Always work with the engine switched OFF.</li> <li>⚠ DO NOT drain oil or coolant when the engine is hot.</li> <li>⚠ DO NOT open the radiator cap when the engine is hot.</li> </ul>	<p><b>2</b></p>  <ol style="list-style-type: none"> <li>a. Check the diesel level indicator located next to the diesel tank filler cap.</li> <li>b. If deemed required, fill diesel in the tank.</li> </ol>	<p><b>3</b></p>  <ol style="list-style-type: none"> <li>a. Open the diesel cap shown above.</li> <li>b. Check the filter located in the inlet for clogging.</li> <li>c. Pour diesel while checking the gauge. Stop when 'FULL'</li> <li>d. Wipe off any excess diesel that might have fallen on the canopy.</li> </ol>
<p><b>4</b></p>  <ol style="list-style-type: none"> <li>a. Position the mast either with the lifting eye facing to the front or the rear of the canopy.</li> <li>b. Open the hood</li> </ol>	<p><b>5</b></p>  <ol style="list-style-type: none"> <li>a. Pull out the oil dipstick from the location shown above.</li> <li>b. Oil level should be between the max and min level.</li> </ol>	<p><b>6</b></p>  <ol style="list-style-type: none"> <li>a. Open the oil filling cap shown by the arrow.</li> <li>b. Pull out the dip stick to allow venting.</li> <li>c. Pour fresh recommended oil of the grade required per section 9.2.3</li> <li>d. Check using the dipstick.</li> <li>e. Stop when level is slightly below the HIGH mark.</li> </ol>
<p><b>7</b></p>  <ol style="list-style-type: none"> <li>a. Check the overflow coolant bottle for coolant level. It should be between the max and min levels.</li> <li>b. Open the radiator cap (ONLY WHEN THE ENGINE IS COOL TO TOUCH) and check the level. It should be up to the bottom of the filler neck.</li> </ol>	<p><b>8</b></p> <ul style="list-style-type: none"> <li>⚠ Before draining, filling or topping off coolant, ALWAYS ensure that the engine is OFF and is COOL to the touch.</li> <li>⚠ Opening the radiator cap of a hot engine can cause scalding hot coolant to spray around and cause serious and life threatening burns.</li> </ul> <ol style="list-style-type: none"> <li>a. To drain coolant from the radiator, follow process listed in section 9.2.5</li> </ol>	<p><b>9</b></p> <ol style="list-style-type: none"> <li>a. To fill or top off the coolant, use the appropriate coolant listed in section 9.2.3</li> <li>b. Open the radiator cap (ONLY WHEN THE ENGINE IS COOL) and carefully pour the coolant until it reaches the bottom of the filler neck.</li> <li>c. Open the overflow bottle and carefully pour the coolant until it reaches the HIGH / MAX mark.</li> </ol>

## 6. MACHINE SETUP

### 6.2 Lamp and lamp cross arm setup

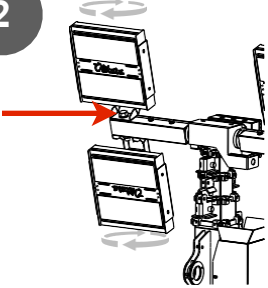
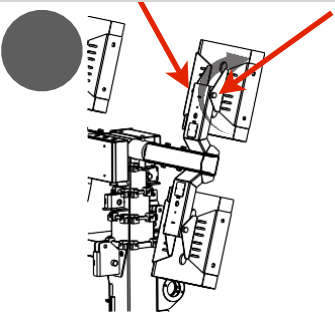
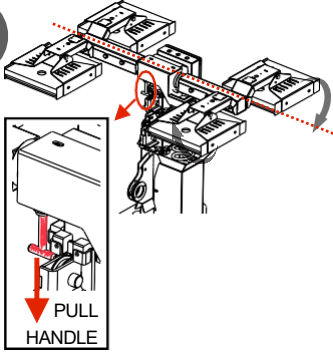
<p><b>1</b></p> <p><b>CAUTION</b></p> <ul style="list-style-type: none"> <li>⚠ Wheels are to be Chocked</li> <li>⚠ Machine stable on level ground</li> <li>⚠ Wear a safety helmet when working on lamps</li> <li>⚠ No obstructions above tower</li> <li>⚠ DO NOT work on tower in high winds or lightning storms</li> </ul>	<p><b>2</b></p>  <ol style="list-style-type: none"> <li>a. Loosen the center bolt.</li> <li>b. This will allow both the top and bottom LED lamp to be rotated in either direction as shown by the arrows.</li> <li>c. Tighten the bolt after adjustment.</li> </ol>	 <ol style="list-style-type: none"> <li>a. Loosen the hinge bolt from both sides of the bracket as shown by the arrows.</li> <li>b. Carefully adjust the lamp position.</li> <li>c. Tighten the bolts.</li> <li>d. This can be done for all lamps.</li> </ol>
<p><b>4</b></p>  <ol style="list-style-type: none"> <li>a. There are 3 positions for the cross light arm; (1) Face Down, (2) 45 deg, (3) 70 deg</li> <li>b. To set, pull tilt handle shown above.</li> </ol>	<p><b>5</b></p> <ol style="list-style-type: none"> <li>a. Pull the tilt handle and gently pull down on the winch side lamps at the same time.</li> <li>b. Let go of the tilt handle and keep tilting the light cross arm until the tilt handle clicks into the first hole (45 deg).</li> <li>c. Redo steps a. &amp; b. until the next position (70 deg) is reached and the pin clicks into the next hole.</li> </ol>	<p><b>6</b></p> <p><b>INTENTIONALLY LEFT BLANK</b></p>
<p><b>INTENTIONALLY LEFT BLANK</b></p>	<p><b>INTENTIONALLY LEFT BLANK</b></p>	<p><b>INTENTIONALLY LEFT BLANK</b></p>

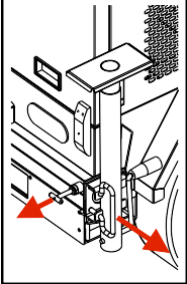
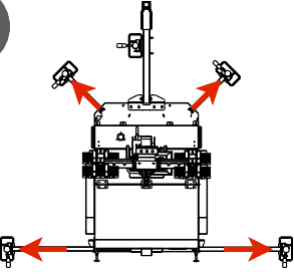
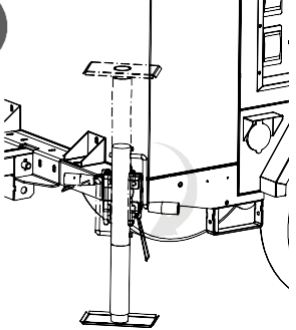
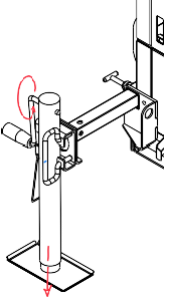
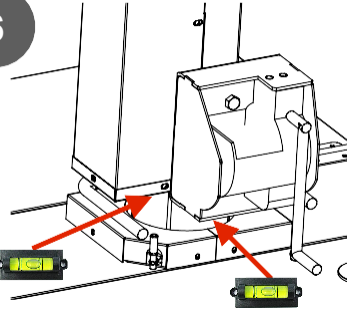

## 6. MACHINE SETUP

### 6.3 Machine levelling

<p><b>1</b></p> <p><b>CAUTION</b></p> <ul style="list-style-type: none"> <li>⚠️ Wheels are to be Chocked</li> <li>⚠️ Machine stable on level ground</li> <li>⚠️ DO NOT work on tower in high winds or lightning storms</li> </ul>	<p><b>2</b></p>  <ol style="list-style-type: none"> <li>a. Pull the spring lock</li> <li>b. At the same time pull on the jack to disengage the outrigger tube from the locking pin.</li> <li>c. Release the pin and gently pull the outrigger tube until the locking pin snaps into the next locking hole.</li> </ol>	<p><b>3</b></p>  <ol style="list-style-type: none"> <li>a. Proceed to pull out all other jack and outrigger tubes from the machine.</li> </ol>
<p><b>4</b></p>  <ol style="list-style-type: none"> <li>a. Rotate and lock jack into the operational position</li> <li>b. Do the same for all jacks.</li> </ol>	<p><b>5</b></p>  <ol style="list-style-type: none"> <li>a. Rotate the jack handle and extend the jack.</li> <li>b. Using the bubble level on the mast extend all the jacks to level the mast.</li> </ol>	<p><b>6</b></p>  <ol style="list-style-type: none"> <li>a. Use the bubble levels on adjacent sides of the mast to ensure that the mast is level.</li> <li>b. It is also important to visually check the mast to ensure that it is not inclined.</li> </ol>
<p><b>INTENTIONALLY LEFT BLANK</b></p>	<p><b>INTENTIONALLY LEFT BLANK</b></p>	<p><b>INTENTIONALLY LEFT BLANK</b></p>



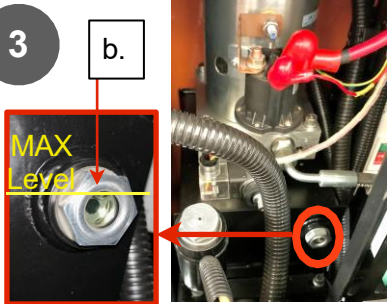

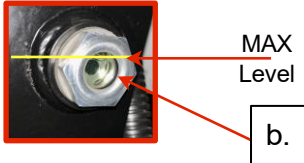

## 6. MACHINE SETUP

### 6.4 Hydraulic mast setup for use (where available)

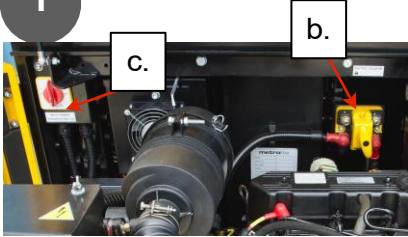
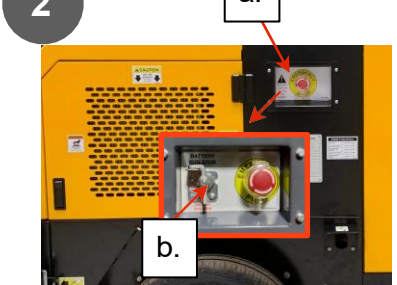
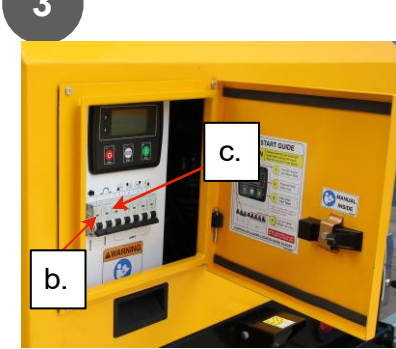
<p><b>1</b></p> <p><b>CAUTION</b></p> <ul style="list-style-type: none"> <li>⚠ Wheels are to be Chocked</li> <li>⚠ Machine stable on level ground</li> <li>⚠ DO NOT check oil level unless mast is fully retracted.</li> <li>⚠ DO NOT fill oil level unless mast is fully retracted. Oil filled when the mast is not retracted will leak out from the unit</li> </ul>	<p><b>2</b></p>  <p>a. Open the hood and locate the hydraulic mast motor fuse located above the hydraulic powerpack.</p> <p>b. Makes sure that the fuse is not blown.</p>	<p><b>3</b></p>  <p>a. Check the oil level in the hydraulic tank by using the view port located on the tank.</p> <p>b. With the mast fully retracted, the oil level should just fully cover the view port.</p>
<p><b>4</b></p> <p>a. Once filled the hydraulic oil rarely needs to be topped up unless there is a leak.</p> <p>b. However, if the oil level drops follow the next steps to top up.</p> <ul style="list-style-type: none"> <li>⚠ DO NOT fill oil level unless mast is fully retracted.</li> <li>⚠ DO NOT WORK on the unit when it is pressurised</li> </ul>	<p><b>5</b></p>  <p>a. To fill oil, open the oil filler plug using a spanner</p> <p>b. Insert a funnel into the tube</p> <p>c. Pour mineral hydraulic oil into the funnel. Refer to section 9.2.3 for correct grade of oil.</p>	<p><b>6</b></p>  <p>a. Check the view port for oil level.</p> <p>b. When the port is just filled with oil, stop filling and fit the oil filler plug back.</p> <p>c. Wipe down the tank and any oil that may have fallen around.</p>
<p><b>7</b></p> <p>Refer to section 7.6 to raise or lower the hydraulic mast</p>	<p><b>INTENTIONALLY LEFT BLANK</b></p>	<p><b>INTENTIONALLY LEFT BLANK</b></p>

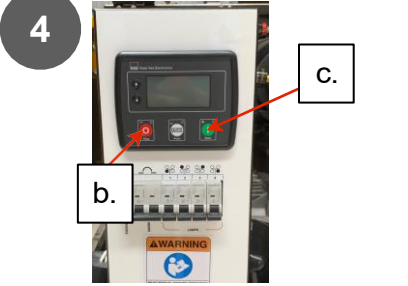
## 7. MACHINE STARTUP / SHUTDOWN

### 7.1 Startup in Genset Power Mode

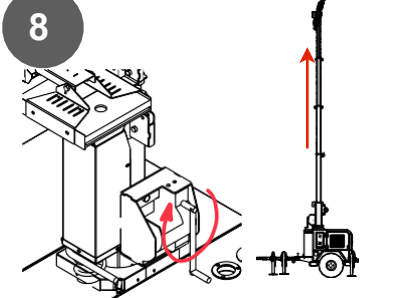
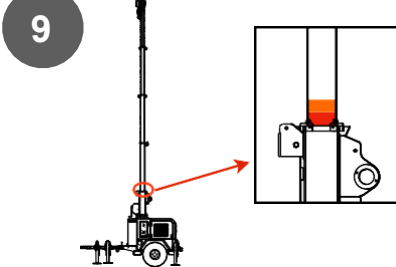
<p><b>1</b></p>  <p>a. Open the hood of the machine  b. Turn ON the battery isolator **  c. Turn the "INPUT POWER TRANSFER SWITCH" to 'GENSET POWER' mode.**  d. Close and lock the hood.</p>	<p><b>2</b></p>  <p>a. Check and release the E stop located on the side of the machine.  b. Turn ON battery isolator if available here.</p>	<p><b>3</b></p>  <p>a. Open the operator window.  b. Switch on Engine MCB   c. Switch on Mains MCB </p>
<p><b>4</b></p>  <p>a. Allow controller to initialise.  b. Press the red "STOP" button once.  c. Press the green "START" button twice.  d. This will begin the engine startup process</p>	<p><b>5</b></p>  <p>a. Once the engine is running, use the arrow keys to navigate and check below values:  A. Voltage = 120V +/-5V each phase  B. Frequency = 60Hz +/- 2Hz</p>	<p><b>6</b></p>  <p>a. Wait for 2 mins or until the Hourglass symbol disappears (whichever is earlier) before starting the lamps</p>
<p><b>7</b></p>  <p>a. Turn on the lamp MCBs one at time. Use the symbols above the MCB to identify the lamp turning on.  <b>Follow sections 5.1 (steps 1-7), 6.2 (steps 1-5) &amp; 6.3 (steps 1-6) to ensure that the machine is properly setup before raising the mast.</b></p>	<p><b>8</b></p>  <p>a. To raise the tower to the desired height, turn the winch handle clockwise.  b. Since the winch is self locking the handle can be left when the desired height is reached.</p>	<p><b>9</b></p>  <p>a. To raise the tower to the maximum height, keep turning the handle until the orange and red sticker comes into view on the tube shown above.  b. <b>Follow sec 7.6 for operating the hydraulic mast</b></p>

# 7. MACHINE STARTUP / SHUTDOWN

## 7.2 Cold Start in Genset Power Mode (If available)

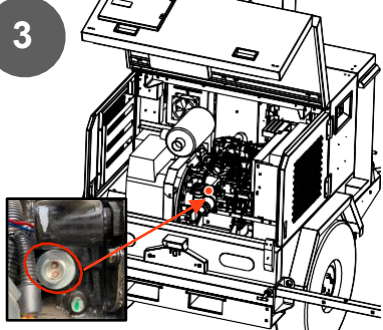
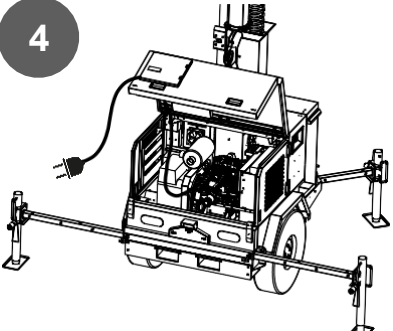
<p><b>1</b></p> <p><b>CAUTION</b></p> <ul style="list-style-type: none"> <li>⚠ Make sure all the snow is cleared from the tail pipe, air inlet and air outlet portions of the canopy.</li> <li>⚠ This is to be done when ambient temperatures are below -15 deg C</li> <li>⚠ Ensure power supply to block heater is protected with appropriate circuit breaker.</li> <li>⚠ DO NOT leave operational for more than 6 hrs</li> </ul>	<p><b>2</b></p>  <ul style="list-style-type: none"> <li>a. Open the hood.</li> <li>b. Remove the heater cord from the manual box located on the hood</li> </ul>	<p><b>3</b></p>  <ul style="list-style-type: none"> <li>a. Locate the block heater socket on the engine block.</li> <li>b. Plug the female side of the heater cord into the socket. Ensure proper fit and tightness.</li> </ul>
<p><b>4</b></p>  <ul style="list-style-type: none"> <li>a. Pass the heater cord thru the operator window. This will allow the hood to be closed.</li> <li>b. Close the hood and start the heating process.</li> </ul>	<p><b>5</b></p> <ul style="list-style-type: none"> <li>a. Once the engine block is sufficiently heated, remove the cord.</li> <li>b. Follow process listed in section 7.1 to startup the machine in GENSET mode.</li> </ul>	<p><b>6</b></p> <p><b>INTENTIONALLY LEFT BLANK</b></p>
<p><b>INTENTIONALLY LEFT BLANK</b></p>	<p><b>INTENTIONALLY LEFT BLANK</b></p>	<p><b>INTENTIONALLY LEFT BLANK</b></p>

## 7. MACHINE STARTUP / SHUTDOWN

### 7.3 Startup in Outside Power Mode (If available)

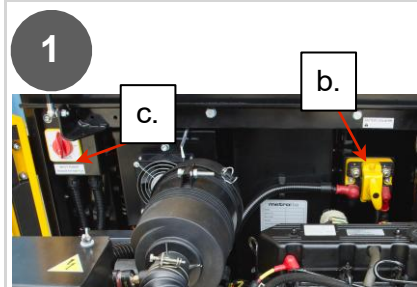

- 1 a. Open the hood of the machine
- b. Turn ON the battery isolator
- c. Turn the "INPUT POWER TRANSFER SWITCH" to 'OUTSIDE POWER' mode.
- d. Close and lock the hood.

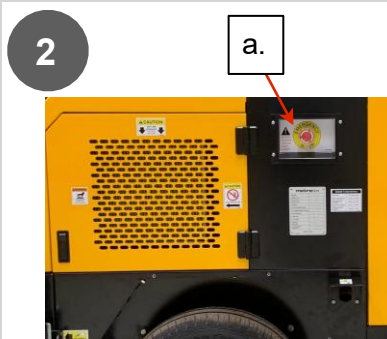

- 2 a. Check and release the E stop located on the side of the machine.

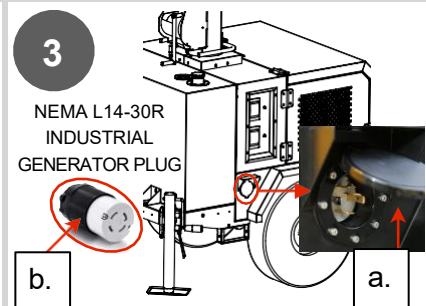

- 3 a. Open the Power Inlet receptacle cover.
- b. With shore power switched OFF, insert the plug type shown above into the socket.
- c. Turn ON the shore power.

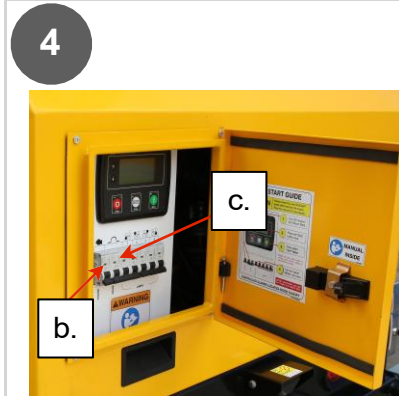

- 4 a. Open the operator window.
- b. Switch on Engine MCB
- c. Switch on Mains MCB

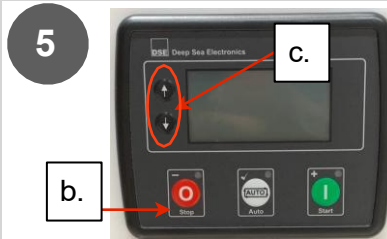

- 5 a. Allow controller to initialise.
- b. Press the red "STOP" button once.
- c. Use the arrow keys to navigate and check below values:
  - A. Voltage P1 & P2 = 120V +/-5V each phase
  - B. Frequency = 60Hz +/- 2Hz

- 6 a. Once the values are correct switch OFF Engine MCB
- b. This will turn off the controller but it will not affect the power input to the lamps. It is important to do this since the hour meter on the controller will increment even in "OUTSIDE POWER" mode and without the engine ON.
- c. Turn ON the engine MCB to power up the controller whenever it is necessary to get voltage or current values. Turn it OFF after getting the values.

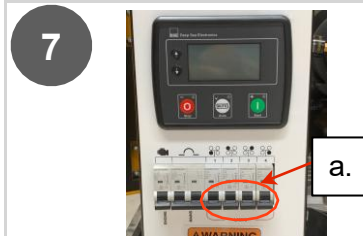

- 7 a. Turn on the lamp MCBs one at time. Use the symbols above the MCB to identify the lamp turning on.

**Follow sections 5.1 (steps 1-7), 6.2 (steps 1-5) & 6.3 (steps 1-6) to ensure that the machine is properly setup before raising the mast.**

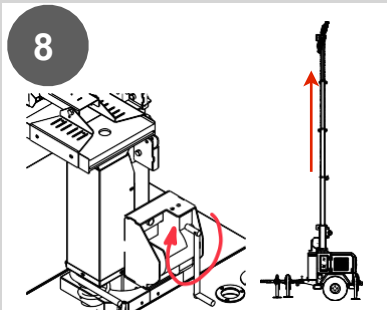

- 8 a. To raise the tower to the desired height, turn the winch handle clockwise.
- b. Since the winch is self locking the handle can be left when the desired height is reached.

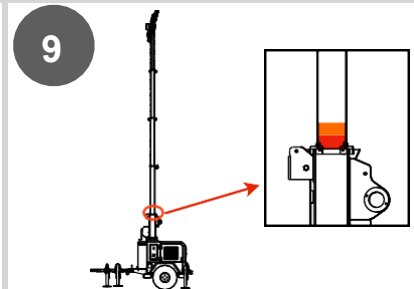

- 9 a. To raise the tower to the maximum height, keep turning the handle until the orange and red sticker comes into view on the tube shown above.
- b. **Follow sec 7.6 for operating the hydraulic mast**





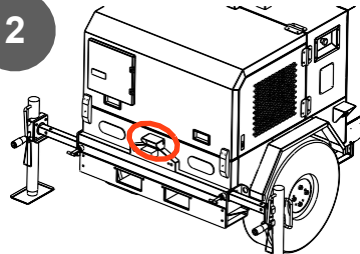
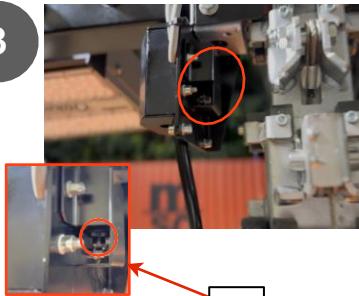
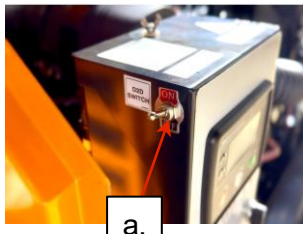
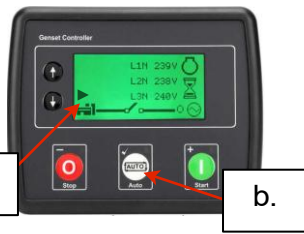

## 7. MACHINE STARTUP / SHUTDOWN

### 7.4 Startup/Shutdown using Dusk to Dawn sensor (If available)

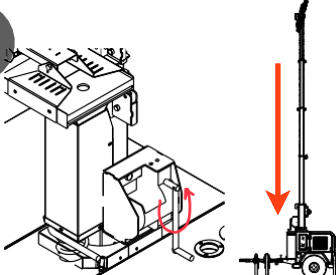
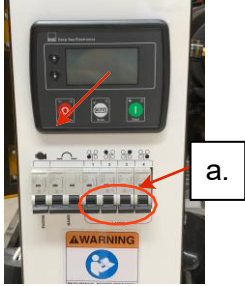
<p><b>1</b></p> <p><b>CAUTION</b></p> <ul style="list-style-type: none"> <li>⚠ This mode only works in 'GENSET POWER' mode.</li> <li>⚠ DO NOT turn OFF lamp MCBs.</li> <li>⚠ Always check on machine periodically if left for remote operation to ensure that the machine is operating safely.</li> </ul>	<p><b>2</b></p>  <p>a. This auto startup/shutdown only works in "GENSET POWER" mode.</p> <p>b. Proceed to setup and startup the machine in "GENSET POWER" mode. See procedure listed in section 7.1</p>	<p><b>3</b></p>  <p>a. This is the location of the D2D sensor.</p> <p>b. Make sure to keep it clean and uncovered for proper operation.</p>
<p><b>4</b></p>  <p>a. Switch on the D2D switch</p> <p>b. Follow Sec. 7.1 process 1 thru 7 to turn on the machine and lights.</p>	<p><b>5</b></p>  <p>a. Wait for the machine to be working normally.</p> <p>b. Press the "AUTO" button on the controller.</p> <p>c. A triangle will show up on the controller indicating the AUTO mode is ON.</p>	<p><b>6</b></p> <p>a. Depending on ambient light condition, the following will happen:</p> <ul style="list-style-type: none"> <li>A. If the ambient lux level is low (like late evening), the triangle symbol will stay on and the machine will continue running.</li> <li>B. If the ambient lux level is high (like early evening), the triangle symbol will disappear and the machine will switch off.</li> </ul>
<p><b>7</b></p> <p>a. When using this method of operation, always make sure that all safety procedures are followed and there is enough of diesel in the system.</p> <p>b. Always make sure to keep the lamp breakers ON even when the machine switches off in the morning to allow the cycle to repeat the next night.</p>	<p><b>8</b></p> <p><b>INTENTIONALLY LEFT BLANK</b></p>	<p><b>INTENTIONALLY LEFT BLANK</b></p>

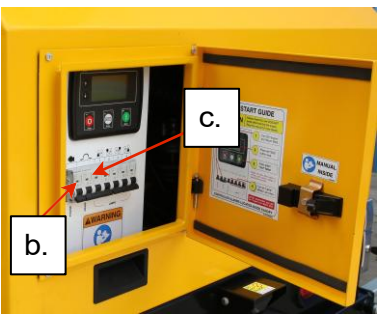
# 7. MACHINE STARTUP /SHUTDOWN

## 7.5 Machine Shutdown process

<p><b>1</b></p> <p><b>CAUTION</b></p> <ul style="list-style-type: none"> <li>⚠ Always wear safety helmet when operating the mast.</li> <li>⚠ Lamps are HOT to touch just after operation.</li> <li>⚠ DO NOT operate mast in lightning storms.</li> </ul>	<p><b>2</b></p>  <p>a. If the tower is extended, then using the winch lower the tower by turning the handle in the counter-clockwise direction.</p> <p>b. Follow process 7.6, steps 5 &amp; 6 to lower a hydraulic mast.</p>	<p><b>3</b></p>  <p>a. Open operator window</p> <p>b. Turn OFF the lamp MCBs one at a time.</p>
<p><b>4</b></p>  <p>a., b.</p> <p>If running the machine in 'Genset power' mode:</p> <p>a. Press the "STOP" red button once for shutdown with cool down sequence.</p> <p>b. Press the "STOP" red button twice quickly for instant shutdown.</p>	<p><b>5</b></p>  <p>b.</p> <p>c.</p> <p>a. Wait for the engine to stop.</p> <p>b. Switch off Engine MCB </p> <p>c. Switch off Mains MCB </p>	<p><b>6</b></p> <p>If running the machine in 'Outside power' mode:</p> <p>a. Turn OFF the mains MCB</p> <p>b. Turn OFF the supply from the outside source to the inlet socket.</p> <p>c. Disconnect the plug from the INLET socket.</p> <p>⚠ DO NOT keep the outside power plug connected to the inlet socket when not in use. It could be a tripping hazard.</p>
<p><b>7</b></p>  <p>a.</p> <p>If the machine is going to be shutdown for an extended period of time:</p> <p>a. Open the hood and turn OFF the battery Isolator</p>	<p><b>8</b></p> <p>a. Press the E-Stop button to keep the machine safe during shutdown.</p>	<p><b>INTENTIONALLY LEFT BLANK</b></p>

## 7. MACHINE STARTUP / SHUTDOWN

### 7.6 Raising and lowering hydraulic mast (If provided)

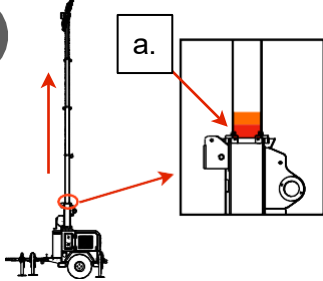
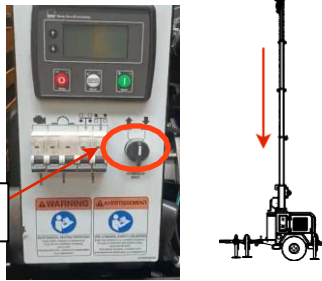
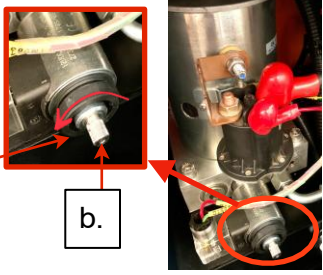
<p style="text-align: center;"><b>1</b></p> <p style="text-align: center;"><b>PROCESS TO RAISE THE HYDRAULIC MAST</b></p>	<p style="text-align: center;"><b>2</b></p> <p>a. Startup the genset using process 7.1, steps 1 to 7. b. Follow process 6.4, steps 1 to 3 to setup the hydraulic mast for operation.</p> <p><b>⚠</b> The genset needs to be ON to be able to raise the hydraulic mast. <b>⚠</b> Only lowering the mast can occur even the machine is OFF. However the battery isolator needs to be ON.</p>	<p style="text-align: center;"><b>3</b></p>  <p>a. To raise the mast turn the switch to the 'UP' direction. b. The mast will start to telescope up.</p>
<p style="text-align: center;"><b>4</b></p>  <p>a. Max tower height is reached when the orange and red sticker comes into view on the tube. b. Depending on the ambient temperature and oil used, it will take around 20 sec to reach full height.</p>	<p style="text-align: center;"><b>5</b></p> <p style="text-align: center;"><b>PROCESS TO LOWER THE HYDRAULIC MAST</b></p> <p><b>⚠</b> Lowering the mast can occur even the machine is OFF. However the battery isolator needs to be ON.</p>	<p style="text-align: center;"><b>6</b></p>  <p>a. To lower the mast, turn the switch on the panel to the 'DOWN' direction. b. The mast will lower until it retracts fully.</p>
<p style="text-align: center;"><b>7</b></p> <p>a. As a safety feature the machine is setup to allow the user to lower the mast even when the engine is switched OFF. b. However it is important to have the battery isolator ON and the starter battery charged and in good condition. c. If the battery is low, replace the battery and retry lowering the mast.</p>	<p style="text-align: center;"><b>8</b></p>  <p>a. To manually lower the mast, use the safety override valve. b. Loosen the knob using an Allen key. c. Turn the knob CCW until the mast starts to lower. Tighten after the mast is fully retracted.</p>	<p style="text-align: center;"><b>INTENTIONALLY LEFT BLANK</b></p>

# 8. POWER OUTLET SOCKETS / RECEPTACLES

## 8.1 Procedure to use Power Outlets / Receptacles

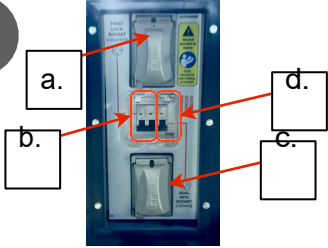
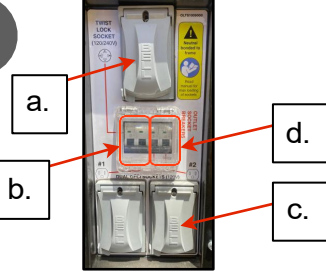
<p><b>1</b></p> <p><b>CAUTION</b></p> <ul style="list-style-type: none"> <li>⚠ HIGH VOLTAGE present at each socket when machine is operational.</li> <li>⚠ Always use proper rated cable for connecting loads to the sockets.</li> <li>⚠ DO NOT exceed the max power allowed per socket.</li> <li>⚠ DO NOT keep socket covers propped open.</li> <li>⚠ DO NOT use the sockets in rains or lightning storms.</li> </ul>	<p><b>2</b></p>  <p>The DLT-4xx machine is provided with</p> <ul style="list-style-type: none"> <li>a. 1 x 30A Twistlock 240V socket</li> <li>b. 1 x 30A 2pole breaker</li> <li>c. 1 x 20A GFCI duplex 120V socket</li> <li>d. 1 x 20A 1 pole breaker for duplex socket</li> </ul>	<p><b>3</b></p>  <p>The DLT-8xx machine is provided with</p> <ul style="list-style-type: none"> <li>a. 1 x 30A Twistlock 240V socket</li> <li>b. 1 x 30A 2pole breaker</li> <li>c. 2 x 20A GFCI duplex 120V socket</li> <li>d. 2 x 20A 1 pole breaker for each of duplex socket</li> </ul>
<p><b>4</b></p> <ul style="list-style-type: none"> <li>a. All sockets / receptacles and associated breakers for both models act in the same way.</li> <li>b. All sockets are powered and available when             <ul style="list-style-type: none"> <li>A. The MAINS MCB is ON</li> <li>B. AND power is available from the engine running in 'Genset power' mode</li> <li>C. OR power is available from an outside source in 'Outside power' mode.</li> <li>D. AND none of the thermal breakers are tripped.</li> </ul> </li> </ul>	<p><b>5</b></p> <ul style="list-style-type: none"> <li>a. MAX wattage available for             <ul style="list-style-type: none"> <li>A. DLT-4C = 1800 W</li> <li>B. DLT-8C = 5000 W</li> </ul> </li> <li>b. For DLT-8C machines, please ensure that the max current of 20A is not exceeded for the GFCI sockets.</li> </ul>	<p><b>6</b></p> <ul style="list-style-type: none"> <li>a. Use only tough rubber insulation flexible cable for connecting the load to the sockets</li> <li>b. The total length of the cable should be &lt; 100m for a 12 gauge cable.</li> </ul>
<p><b>7</b></p> <p>Manual test process to test a GFCI socket</p> <ul style="list-style-type: none"> <li>a. Turn on power to the GFCI socket.</li> <li>b. Push the test button. This will cause the reset button to pop out.</li> <li>c. Check supply from the socket. It should be OFF.</li> <li>d. Push the rest button in. This will resume power from the socket.</li> <li>e. If the red light on the socket is flashing, replace the GFCI socket</li> </ul>	<p><b>8</b></p> <p><b>INTENTIONALLY LEFT BLANK</b></p>	<p><b>9</b></p> <p><b>INTENTIONALLY LEFT BLANK</b></p>

## 8. POWER OUTLET SOCKETS / RECEPTACLES

### 8.2 Derating information for genset power

The genset KVA rating is derived from the engine power which has its nominal values based on ISO 15550 conditions as:

1. Altitude = Sea level
2. Barometric pressure = 100kPa
3. Air temperature = 298K or 25 deg C or 77 deg F
4. Relative humidity = 30%

There will be a change to the output power when the machine is operated in a condition that is different from the standard conditions. Please use the below approximations to calculate the available power from the genset:

#### EFFECT OF ALTITUDE ON POWER

Use the chart below to approximately de-rate the output power due to altitude of operation.

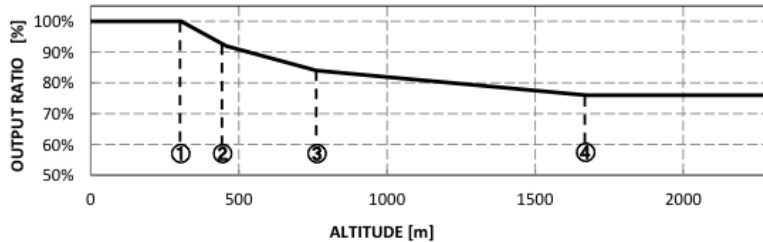

	ALTITUDE (m)	OUTPUT RATIO (%)
①	~300	100
②	450	92
③	760	84
④	1700~	76

#### EFFECT OF AMBIENT TEMPERATURE ON POWER

There will be an approximate decrease of 2% in output power based on an increase of 10 deg C in ambient temperature from the nominal or 25 deg C. (Eg. if the ambient temperature increases by 10 deg C from 25 deg C to 35 Deg C, the output power will reduce by 2%.)

Ageing of oil and overall engine, blockage of the radiator core, increase of humidity also reduces the output power of the engine. Hence it is important to always perform the required maintenance at the recommended service intervals and keep the engine clean to gain the most from the engine.

## 9. GENERAL MAINTENANCE

### 9.1 Overall machine maintenance

#### 9.1.1 Checklist to prep for machine maintenance

- Machine is on level ground and has its wheels chocked
- All external power supply wires have been disconnected from the machine
- Any wires from the power outlets are disconnected
- Emergency Stop button is activated and locked/tagged.
- Battery Isolator switch is in the OFF position
- All MCBs are in the OFF position
- If there is any welding work or major electrical work being done on the machine, disconnect the battery negative wire from the battery.

### WARNINGS



Do not perform any maintenance on the machine when the machine is running.



Do not work on electrical components when standing in water or in rainy conditions.

#### 9.1.2 Maintenance schedule for proper machine use

ACTION	DAILY / BEFORE USE	MONTHLY	EVERY 6 MONTHS
Check mast for damage	X		
Check wire ropes for fraying	X		
Check winch drum to make sure wire is properly wound	X		
Check lamp connections for damage or disconnection	X		
Check tires. Fill air if necessary.	X		
Check electrical connections inside the machine	X		
Check all engine fluids. Top up if necessary.	X		
Check battery condition. Replace if not charging			X
Drain bunds for engine bay and diesel tank.		X	
Clean inside of canopy		X	
Clean outside of machine		X	

## 9. GENERAL MAINTENANCE

### 9.2 Engine maintenance

#### 9.2.1 Mitsubishi L2E & L3E engine





This section covers the basic maintenance that is required for the Mitsubishi L series, 2 cylinder and 3 cylinder engines.

For additional information or detailed information please see the engine service manual.

ACTION	FREQUENCY (Action to be taken every XX hrs)				
	100	250	500	1000 / Yearly	As required
Check fuel lines and clamps	X				
Check for engine fluid leaks in the drip/bund tray	X				
Check coolant level in radiator and overflow bottle	X				
Clean air filter element		X			
Check fan belt tension			X		
Change oil and oil filter*			X		
Change fuel filter*			X		
Clean radiator core			X		
Check Battery			X		
Replace air filter element				X	
Replace fan belt				X	

#### IMPORTANT:



It is very important to change the **OIL and OIL FILTER after the first 50 hrs runtime of the engine**. This initial service is required to ensure all the initial wear particles from the engine cylinder are removed. All service after can be done per the table below:

-  DO NOT start the engine if the oil level is below the low level of the dipstick.
-  DO NOT overfill oil in the engine.
-  Always make final oil measurement atleast 30 mins after engine has run.
-  Dusty, hot and humid conditions will require a more frequent service interval as listed above.
-  It is very important to use Ultra Low Sulphur diesel in the fuel tank.

## 9. GENERAL MAINTENANCE

### 9.2.2 Maintenance Alarms on Controller

The DSE controller is programmed to alert the user for engine maintenance every 500 run hours of the engine. This will pop up on the screen with the wrench symbol. After performing the required servicing, press and hold the RED (STOP) button on the controller until the alarm symbol disappears.

	OIL FILTER MAINTENANCE ALARM
	AIR FILTER MAINTENANCE ALARM
	FUEL FILTER MAINTENANCE ALARM

**A reset can also be done before the alarm shows** by going to the page on the controller that shows the maintenance alarm and pressing the RED (STOP) button. If a code is required on the controller, please contact your nearest dealer for the code to reset the alarm.

### 9.2.3 Oil, coolant and diesel details

	X-DLT-4XX	X-DLT-8XX
<b>OIL CAPACITY (Standard)</b>	0.66 gal (2.5 liters)	0.97 gal (3.7 liters)
<b>OIL CAPACITY (Ext run)</b>	0.89 gal (3.4 liters)	1.2 gal (4.7 liters)
<b>OIL GRADE (&gt; -10 deg C)</b>	15W-40 CH4/C14*	
<b>OIL GRADE (&lt; -10 deg C)</b>	10W-30* or 5W-40*	
<b>HYDRAULIC OIL CAPACITY</b>	1.2 gal (4.8 liters)	
<b>HYDRAULIC OIL (&gt; -25 deg C)</b>	Mineral oil Grade 32	
<b>HYDRAULIC OIL (&lt; -25 deg C)</b>	Mineral oil grade suitable upto -50C**	
<b>COOLANT CAPACITY</b>	0.32 gal (1.2 liters)	0.45 gal (1.8 liters)
<b>COOLANT GRADE</b>	Ethylene glycol, Anti freeze, Anti Corrosive & Non Amine premix	
<b>DIESEL CAPACITY (Ext run)</b>	45 gal (170 liters)	
<b>DIESEL TYPE</b>	Low Sulphur	

\* DO NOT mix different grades of oil. Always completely drain all oil inside engine before replacing oil with a different grade.

\*\* When replacing the hydraulic oil with a different grade, ensure to remove as much of the oil in the hydraulic tank. It is not recommended to mix oil of different grades in ratios > 30%.

 DO NOT spill used oil on the ground when draining oil from the oil sump. Always collect the used oil in a container and dispose according to local laws and regulations.

 If coolant enters the eyes or mouth, wash and seek immediate medical attention.





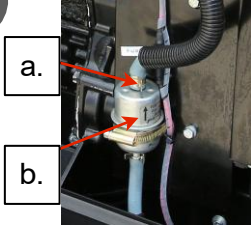
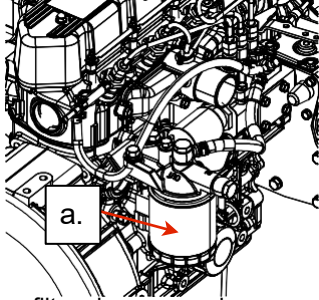
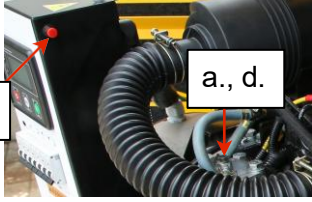
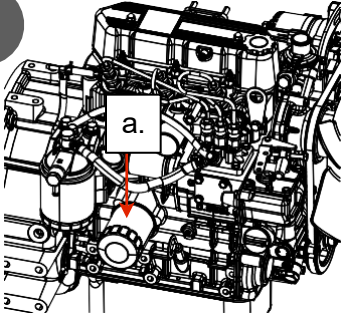
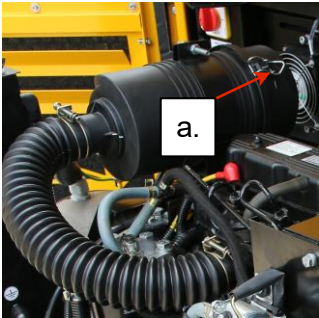

## 9. GENERAL MAINTENANCE

### 9.2.4 Filter change process

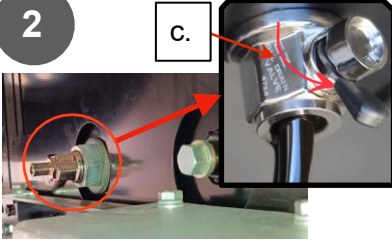
<p><b>1</b></p>  <p>a. Remove the fuel tube clamps from the pre-filter. b. Change the pre-filter with a new filter. c. Fit the clamps back on the pre-filter</p>	<p><b>2</b></p>  <p>a. Using a filter clamp wrench, clamp the filter cartridge and unscrew the cartridge from the filter mount. b. Apply a little oil on the new filter O-ring and screw it on the filter mount.</p>	<p><b>3</b></p>  <p>a. Loosen the black air vent bolt on top of the diesel filter b. Turn on the engine MCB c. Press the fuel pump override button and pump diesel thru the pipes and remove the air from the system. d. After running it for around 30 secs, tighten the bolt and leave the button.</p>
<p><b>4</b></p>  <p>a. Using the oil filter clamp wrench, unscrew the oil filter cartridge. Make sure there is a cloth placed under the oil cartridge to catch the oil spill</p>	<p><b>5</b></p> <p>a. Apply a little oil on the new filter O-ring and screw it back into the holder.</p>	<p><b>6</b></p> <p>a. Start the engine and check for leaks around the oil filter.</p>
<p><b>7</b></p>  <p>a. Open the cover for the air filter</p>	<p><b>8</b></p> <p>a. Carefully remove the air filter cartridge by pulling it out of the housing.</p>	<p><b>9</b></p> <p>a. Insert new air filter cartridge into the housing. b. Shut the cap and clip it together tightly.</p>

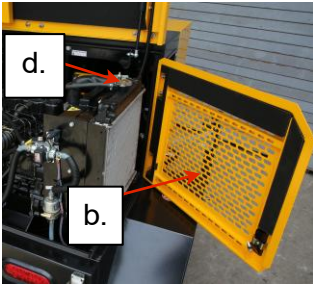
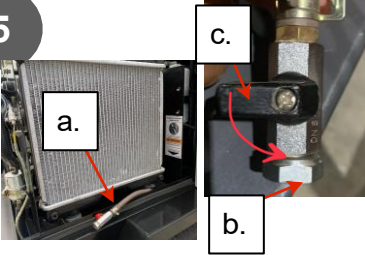
## 9. GENERAL MAINTENANCE

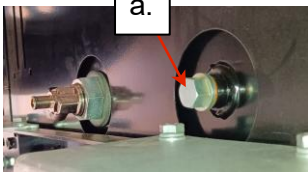
### 9.2.5 Draining oil, coolant and bund trays

<p><b>1</b></p>  <ol style="list-style-type: none"> <li>Insert plastic tray underneath the forklift pockets at the rear of the trailer in the area between the red lines.</li> <li>Pull the dip stick out.</li> <li>DO NOT drain hot oil. It can cause serious burns. Wait for the engine to cool.</li> </ol>	<p><b>2</b></p>  <ol style="list-style-type: none"> <li>Insert gloved hand underneath the pocket and feel for the drain valve located underneath the engine section of the trailer.</li> <li>Look at decal to identify the valve.</li> <li>Pull and turn the valve cock 90 deg to start the flow of oil.</li> </ol>	<p><b>3</b></p>  <ol style="list-style-type: none"> <li>Once the oil has drained completely, turn the lever of the valve to the closed position.</li> <li>It should snap back. Without pressing the lever, wiggle the lever to check that it is properly closed.</li> <li>Push the dip stick back in.</li> </ol>
<p><b>4</b></p>  <ol style="list-style-type: none"> <li>DO NOT drain the coolant when engine is hot.</li> <li>Open hood and the side door on the radiator side.</li> <li>Use a plastic tray to collect the coolant</li> <li>Open the radiator cap.</li> </ol>	<p><b>5</b></p>  <ol style="list-style-type: none"> <li>Pull out the tube with the radiator coolant drain valve. It will be normally secured with a Velcro strap to the side of the radiator.</li> <li>Remove the drain plug.</li> <li>Turn the valve cock to the flow position to allow the coolant to drain out into the plastic tray</li> </ol>	<p><b>6</b></p> <ol style="list-style-type: none"> <li>Once the coolant has completely drained, close the valve cock completely.</li> <li>Insert and tighten the drain plug on the drain valve.</li> <li>Secure the pipe using the Velcro strap.</li> <li>Close the tighten the radiator cap</li> </ol>
<p><b>7</b></p>  <ol style="list-style-type: none"> <li>To drain the bund tray underneath the engine, push a tray underneath the rear right side (engine side) forklift pocket.</li> </ol>	<p><b>8</b></p>  <ol style="list-style-type: none"> <li>Locate the drain plug (M14x1.5) underneath the trailer. It can be accessed by inserting the #16 box spanner thru the forklift pocket hole.</li> <li>After draining the bund, insert and re-tighten the drain plug properly.</li> </ol>	<p><b>9</b></p>  <ol style="list-style-type: none"> <li>To drain the fuel tank bund box, locate the drain plug on the bottom of the trailer on the side of the fuel tank box. A decal will show the position.</li> <li>Use a #16 spanner and open the drain bolt to drain into a plastic tray.</li> <li>Re-tighten the drain bolt when completed.</li> </ol>



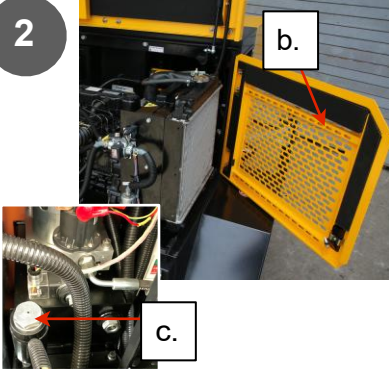
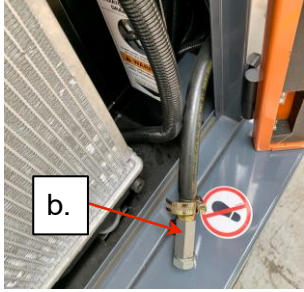
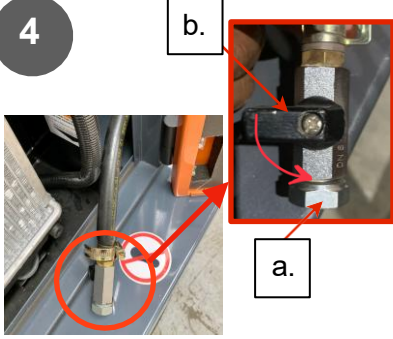
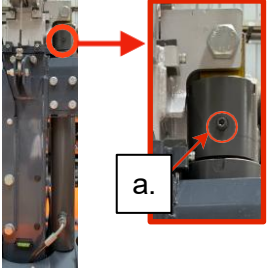
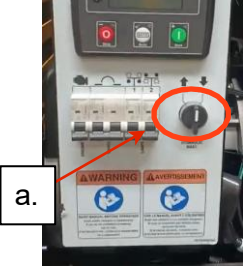

## 9. GENERAL MAINTENANCE

### 9.3 Hydraulic Mast maintenance

<p><b>1</b></p> <p><b>CAUTION</b></p> <ul style="list-style-type: none"> <li>⚠ Wheels are to be Chocked</li> <li>⚠ Machine stable on level ground</li> <li>⚠ DO NOT drain oil unless mast is fully retracted.</li> <li>⚠ DO NOT work on hydraulic unit when pressurised.</li> <li>⚠ To de-pressurise the system, retract the cylinder fully.</li> </ul>	<p><b>2</b></p>  <p>a. Open the hood. b. Open the radiator side door. c. Open the oil filler plug</p>	<p><b>3</b></p>  <p>a. Locate the hydraulic drain pipe in the space right of the radiator bracket and pull it out. b. Prepare a drain tray having a minimum volume of 5 liters.</p>
<p><b>4</b></p>  <p>a. Remove the drain plug. b. Turn the valve cock to the 'flow' position to allow the oil to drain out into the drain tray.</p>	<p><b>5</b></p> <p>a. Once the oil has completely drained, close the valve cock completely. b. Insert and tighten the drain plug on the drain valve. c. Push the pipe back into the space on the right of the radiator bracket. d. Follow process listed in section 6.4, steps 4 to 6 to refill the oil of the appropriate grade.</p>	<p><b>6</b></p> <p>a. If any fittings are loosened on the hydraulic circuit, or the hydraulic tubing / cylinder is replaced, it becomes necessary to bleed air from the hydraulic circuit. b. Follow the process listed ahead to bleed air from the circuit.</p>
<p><b>7</b></p>  <p>a. Locate the drain plug, and loosen using an Allen key. DO NOT remove plug. b. Wrap a cloth underneath the plug around the cylinder top to catch the flow of oil.</p>	<p><b>8</b></p>  <p>a. Turn the switch to the 'UP' direction. This will start a frothy flow of oil from the air vent hole. b. Once the froth stops and oil starts to flow out, release the switch and immediately tighten the plug.</p>	<p><b>9</b></p> <p>a. Continue to raise the tower to the max height. Then lower tower. b. Continue the above cycle a couple of times to ensure that all the air is out of the hydraulic circuit. c. If needed repeat steps 7 and 8. ⚠ Ensure that all the hydraulic fittings are tighten properly to avoid air inlet or oil leakage.</p>

## 10. TROUBLESHOOTING

This section addresses the common problems that arise when using this light tower. The troubleshooting guide is meant to be a first level analysis and guide to resolving basic issues that prevent a trouble free operation of the machine. For any detailed or major issues that are not listed in this guide, it is recommended that the nearest service center or dealer is contacted.

-  Risk of burns when working on engine while operational.
-  Risk of injury due to rotating components. Always make sure that proper care is taken to keep hands and limbs away from rotating components of the engine.
-  Risk of electrocution when the machine is operational and electrical covers are open. Always ensure that the machine is properly grounded when diagnosing the electric issues.
-  Numerous pinch points in the mast and winch can cause severe injury to fingers. Always use gloves.

PROBLEM	CAUSE	REMEDY
Controller does not turn on	Engine' MCB is in the OFF position	Turn ON the 'ENGINE' MCB
	E-Stop is active	Twist and pull the E stop to deactivate
	Battery isolator is switched off	Turn ON the battery isolator
	Battery is discharged	Replace / recharge the battery
	Battery wire is disconnected from battery terminal	Connect and ensure both battery wires are connected firmly to battery terminals
	Fuse is blown	Replace fuse. Fuse chart is present inside the panel
	Controller is disconnected inside panel	Connect the controller and ensure all wires are tight in the connectors
	Battery negative wire to panel is disconnected	Make sure battery wire is connected on both inside and outside the panel. Trace the path of the negative wire to ensure proper connection to the battery negative terminal
Engine does not crank when controller start button is pressed	Wire from panel to starter is disconnected	Connect the wire to the starter
	Starter motor is faulty	Replace the starter motor
	Battery voltage is very low	Replace / recharge the battery
	Controller program is corrupted	Reload the program into the controller
No fuel	No fuel	Fill fuel in the diesel tank. Follow process #3 in section 9.2.3 to remove air from the fuel line.
	Clogged fuel filter	Replace fuel filters. Follow process #1, #2 in section 9.2.3

PROBLEM	CAUSE	REMEDY
<p>Engine cranks but does not start when controller start button is pressed</p> <p>OR</p> <p>Engine starts but shuts down in less than a minute</p>	Fuel electric pump is not working	Turn OFF battery isolator, disconnect electric pump and replace with new pump. Turn ON the battery isolator
	Air in the fuel line	Follow process #3 from section 9.2.3 to remove the air.
	Mains' MCB is in the OFF position	Turn ON the 'MAINS' MCB
	Power inlet selector switch is in 'Outside power' mode or in OFF mode	Turn the switch to 'GENSET POWER' mode.
	Alternator capacitor is faulty	Replace alternator capacitors
	Alternator wire is disconnected from the AC circuit	Connect the alternator wires to the terminal blocks. Exercise extreme caution with working with this circuit. HIGH VOLTAGE is present and can cause serious injury.
	Controller fault alarm	Check the fault symbol from the list pasted on the document holder or in this manual in section 4.4
<p>No alternator / generator output</p>	Faulty capacitor	Replace alternator capacitors
	Mains MCB is in the OFF position	Turn ON the 'MAINS' MCB
	Faulty alternator/generator	Replace alternator/generator
	Low engine rpm due to lack of fuel	Fill fuel in the diesel tank. Follow process #3 in section 9.2.3 to remove air from the fuel line.
	Low engine rpm due to loose rpm setting lever (only in L2E engine model)	Turn on engine. Carefully turn the bolt on the speed lever until the speed / frequency reached 1800 rpm / 60Hz. Tighten the locking nut.
<p>Low oil pressure fault</p>	Oil level in engine is below requirement	Fill / top up oil in the engine sump. Follow process #4, #5, #6 in section 6.1
	Low oil pressure switch is faulty	Replace low oil pressure switch
<p>Engine coolant high temperature fault</p>	Coolant level is below requirement	Fill / top up the correct premix coolant by following process #7, #8, #9 in section 6.1
	Coolant mix is not correct	Ensure the correct coolant premix is used. Plain water will not work as effectively as the premix coolant
	Excessive electrical auxiliary load is being applied to the machine	Remove the excess load. Please refer to block #5 in section 8.1 and section 8.2 for details on max available power for auxiliary load.
	Air inlet to the canopy is being restricted	Ensure there is no obstructions outside the canopy preventing proper air flow. The engine should have access to clean cool air. Also ensure that the filter foam is clean and dust free

PROBLEM	CAUSE	REMEDY
	Air outlet from the radiator out of the canopy is being restricted	Ensure there are no obstructions in front of the radiator outlet that prevent the flow of hot air.
Engine Underspeed / Generator under voltage / Generator under frequency (Hz)	Fuel flow is restricted	Make sure that the fuel lines are not kinked or twisted. Check fuel pump is working properly.
	Fuel filter is clogged	Replace fuel filters. Follow process #1, #2 in section 9.2.3
	Speed setting (only on L2E engine model) lever is loose and reset at a lower rpm setting	Turn on engine. Carefully turn the bolt on the speed lever until the speed / frequency reached 1800 rpm / 60Hz. Tighten the locking nut.
	Alternator/ generator capacitor is faulty	Replace alternator capacitors
	Controller speed setting is incorrect	Contact service center or dealer for help on correcting the speed setting
Engine Overspeed / Generator Over voltage / Generator over frequency (Hz)	Speed setting (only on L2E engine model) lever is set at a higher rpm setting	Turn on engine. Carefully turn the bolt on the speed lever until the speed / frequency reached 1800 rpm / 60Hz. Tighten the locking nut.
	Governor (only on L2E engine model) is faulty	Contact service center or dealer for help.
	Controller speed setting is incorrect	Contact service center or dealer for help on correcting the speed setting
Lamp will not light when MCB turned on	MCB is faulty	Replace MCB
	Voltage is not correct	Using a multimeter check incoming voltage (genset or outside power). Check frequency and speed and then follow above troubleshooting process to fix the issue.
	LED driver is faulty	Contact service center to replace faulty LED driver
	LED module is faulty	Replace faulty LED module
	LED connector at top of mast is loose	Re-connect the LED connector or replace connector if faulty
	LED wiring is faulty	Contact service center for help to trace fault in LED wiring
	Spiral cable is damaged internally	Replace Spiral cable
Machine does not start / stop with Dusk to dawn sensor at dusk / dawn	Dawn to Dusk (D2D) sensor cover fully open	Follow process in section 7.4 to set the D2D sensor cover
	D2D sensor front shield not present	Contact Service center or dealer for front shield
	Stray light falling on the sensor	Move the machine to a new location or block stray light from activating the sensor

PROBLEM	CAUSE	REMEDY
Machine does not start / stop with Dusk to dawn sensor at dusk / dawn	AUTO' button on controller not ON	Press the AUTO button.
	D2D sensor wiring faulty	Contact service center for help in tracing the fault in the D2D sensor wiring
	D2D sensor is faulty	Replace the D2D sensor
	Controller is faulty	Replace the controller.

# 11. NOTES



**END OF MANUAL**