

# megagen



**ELECTRIC POWER  
GENERATOR  
MODEL x48  
OPERATOR'S MANUAL**

# **megagen LIMITED WARRANTY**

## **GENERAL TERMS AND CONDITIONS**

The product warranty is subject to the manufacturer's general terms and conditions of sale.

Acknowledgment of the warranty depends on the strict and proven observance of the operating instructions in this operator's manual and application of the correct mechanical and electro-technical practices.

The warranty will not be valid in the event of:

- Tampering with the generator (modifications without prior authorisation);
- Breakdown due to lack of or inadequate protection and/or incorrect connection;
- Breakdown caused by exceeding the rating plate limits;
- Normal wear and tear of the generator;
- Non-compliance by the personnel in charge of installation of the operational regulations given;
- Accidental causes, natural disasters of every kind, e.g., fires, floods, water or lightning;
- It is the customers responsibility to register the unit engine with the respective OEM to obtain warranty;

The warranty provides that:

- Repair and replacement must be carried out by manufacturer or authorized dealer-
- Components of a different manufacturer (OEM) as engines, alternators, control units and batteries will not be under our warranty and we have no responsibility for the OEM warranties.
- Sales taxes and unexpected costs related to travel, repair and rental are not under warranty
- Maintenance is not included.

The faulty material shall be sent carriage paid to the manufacturer, which reserves the right to pass unquestionable judgement on the reason for the defect.

The warranty applies solely to resetting the original specifications of the product and does not cover any damage to people or objects.

Warranty period from shipment date:

4 years with a limit of 4000 working hours, whichever comes first.

## **SPARE PARTS**

Spare parts manual is available for this unit.

## **WARRANTY VOID IF NOT REGISTERED**



## ELECTRIC POWER GENERATOR

### WARRANTY REGISTRATION FORM & INSPECTION REPORT

#### WARRANTY REGISTRATION

This form must be filled out by the dealer and signed by both the dealer and the customer at the time of delivery.

Customer's Name \_\_\_\_\_ Dealer's Name \_\_\_\_\_  
 Address \_\_\_\_\_ Address \_\_\_\_\_  
 City, State/Prov., Code \_\_\_\_\_ City, State/Prov., Code \_\_\_\_\_  
 Phone Number ( \_\_\_\_\_ ) \_\_\_\_\_  
 Generator Model \_\_\_\_\_  
 Serial Number Alternator \_\_\_\_\_  
 Unit Serial Number \_\_\_\_\_  
 Serial Number Engine \_\_\_\_\_  
 Delivery Date \_\_\_\_\_

#### DEALER INSPECTION REPORT

\_\_\_\_\_ Tire Pressure Checked (If on trailer)  
 \_\_\_\_\_ Wheel Bolts Torqued (If on trailer)  
 \_\_\_\_\_ Inspect Electrical System  
 \_\_\_\_\_ Lubricate Machine  
 \_\_\_\_\_ Check Engine Fluid Levels

#### SAFETY

\_\_\_\_\_ Guards/Shields Installed & Secured  
 \_\_\_\_\_ All Decals Installed & Legible  
 \_\_\_\_\_ Safety Chain on Hitch (If on trailer)  
 \_\_\_\_\_ Review Operating and Safety Instructions

I have thoroughly instructed the buyer on the above described equipment which review included the Operator's Manual content, equipment care, adjustments, safe operation and applicable warranty policy.

Date \_\_\_\_\_ Dealer's Rep. Signature \_\_\_\_\_

Signature \_\_\_\_\_

The above equipment and Operator's Manual have been received by me and I have been thoroughly instructed as to care, adjustments, safe operation and applicable warranty policy.

Date \_\_\_\_\_ Owner's Signature \_\_\_\_\_

WHITE	YELLOW	PINK
AXIOM EQUIPMENT	DEALER	CUSTOMER

# SERIAL NUMBER LOCATIONS

Always give your dealer the serial number of your **megagen** x48 generator when ordering parts or requesting service or other information.

The serial number plates are located where indicated. Please mark the number in the space provided for easy reference.

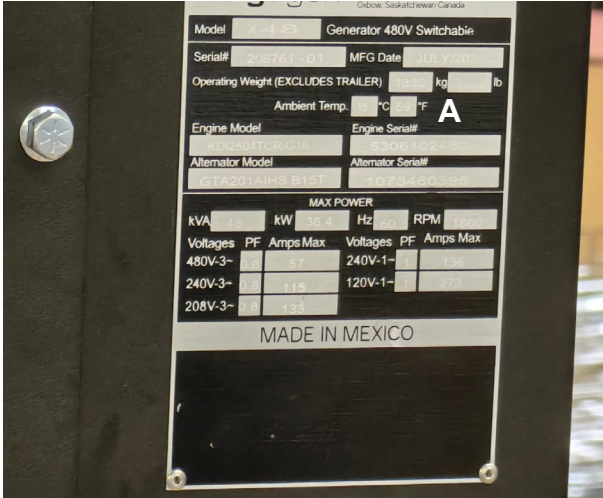

**MACHINE**



**ALTERNATOR**



**ENGINE**

**ENGINE**

Model Number \_\_\_\_\_

Serial Number    Machine    A    \_\_\_\_\_

   Engine    B    \_\_\_\_\_

   Alternator    C    \_\_\_\_\_



# TABLE OF CONTENTS

SECTION	DESCRIPTION	PAGE
<b>1</b>	<b>Introduction .....</b>	<b>7</b>
<b>2</b>	<b>Safety .....</b>	<b>8</b>
2.1	General Safety .....	9
2.2	Equipment Safety Guidelines .....	10
2.3	Safety Training .....	11
2.4	Safety Signs.....	11
2.5	Storage Safety .....	11
2.6	Preparation Safety .....	12
2.7	Installation Safety .....	12
2.8	Maintenance Safety .....	13
2.9	Lock-Out Tag-Out Safety.....	13
2.10	Battery Safety .....	13
2.11	Operating Safety .....	14
2.12	Tire Safety.....	14
2.13	Transport Safety.....	14
2.14	Electrical Safety .....	14
2.15	Diesel Engine Safety .....	15
2.16	Refueling Safety.....	15
2.17	Sign-Off Form .....	16
<b>3</b>	<b>Safety Sign Locations .....</b>	<b>17</b>
<b>4</b>	<b>Operation.....</b>	<b>18</b>
4.1	To the New Operator or Owner .....	18
4.2	Machine Components.....	19
4.3	Machine Break-In.....	0.
4.4	Pre-Operation Checklist.....	0.
4.5	Controls .....	21
4.6	Machine Preparation.....	24
4.7	Operation .....	28
<b>2,6</b>	Storage .....	33
<b>2,7</b>	Transport.....	34
<b>5</b>	<b>Service and Maintenance.....</b>	<b>36</b>
5.1	Service.....	36
5.2	Maintenance .....	42
<b>6</b>	<b>Trouble Shooting .....</b>	<b>46</b>
<b>7</b>	<b>Specifications.....</b>	<b>47</b>
7.1	Mechanical.....	47
7.2	Bolt Torque.....	48
7.3	Electrical Schematic .....	49
<b>8</b>	<b>Index .....</b>	<b>55</b>



# 1 INTRODUCTION

Congratulations on your choice of a megagen x48 generator and welcome to **megagen**'s quality line of generating equipment. This equipment is designed and manufactured to meet the needs of a discriminating buyer in the industry for generation of electric power.

Safe, efficient and trouble free operation of your new **megagen** x48 generator requires that you, and anyone else who will be operating or maintaining the machine, read, understand and practice ALL of the Safety, Operation, Maintenance and Trouble Shooting recommendations contained within this Operator's Manual.



**megagen**

This manual applies to all x48 generator manufactured by **megagen**. Certain options may be available to specifically tailor the generator to your operation and may not be included in this manual. Please contact the manufacturer regarding additional information about these options. Use the Table of Contents and Index as a guide to find specific information.

The information in this manual is accurate based on products produced at the time of publication. The manufacturer reserves the right to make technical updates, corrections and product revisions at any time without notice.

The warnings in this manual and on decals on the unit are not all inclusive. If using a procedure or operating techniques that the manufacturer does not specifically recommend, verify that it is safe for others. Also, make sure the procedure does not render the equipment unsafe.

Keep this manual handy for frequent reference and so that it will be passed on to new operators or owners. Call your megagen dealer if you need assistance, information or additional copies of this manual.

## 2 SAFETY

### SAFETY ALERT SYMBOL

This Safety Alert symbol means  
**ATTENTION! BECOME ALERT!  
YOUR SAFETY IS INVOLVED!**



The Safety Alert symbol identifies important safety messages on your **megagen** generator and in the manual. When you see this symbol, be alert to the possibility of personal injury or death. Follow the instructions in the safety message.

**Why is SAFETY important to you?**

#### 3 Big Reasons

**Accidents Disable and Kill  
Accidents Cost You Money  
Accidents Can Be Avoided**

#### **SIGNAL WORDS:**

Note the use of the signal words **DANGER**, **WARNING** and **CAUTION** with the safety messages. The appropriate signal word for each message has been selected using the following guide-lines:

- |                  |  |
|------------------|--|
| <b>DANGER -</b>  | Indicates an imminently hazardous situation that, if not avoided, will result in death or serious injury. This signal word is to be limited to the most extreme situations, typically for machine components that, for functional purposes, cannot be guarded. |
| <b>WARNING -</b> | Indicates a potentially hazardous situation that, if not avoided, could result in death or serious injury, and includes hazards that are exposed when guards are removed. It may also be used to alert against unsafe practices.                               |
| <b>CAUTION -</b> | Indicates a potentially hazardous situation that, if not avoided, may result in minor or moderate injury. It may also be used to alert against unsafe practices.   |

If you have any questions not answered in this manual or require additional copies or the manual is damaged, please contact your dealer or **megagen**, Phone: 844-732-9466, Email: [service@axiomequipmentgroup.com](mailto:service@axiomequipmentgroup.com).



## SAFETY

**YOU** are responsible for the **SAFE** operation and maintenance of your **megagen** generator. **YOU** must ensure that you and anyone else who is going to operate, maintain or work around the machine be familiar with the operating and maintenance procedures and related **SAFETY** information contained in this manual. This manual will take you step-by-step through your working day and alerts you to all good safety practices while operating the generator.

Remember, **YOU** are the key to safety. Good safety practices not only protect you but, also the people around you. Make these practices a working part of your safety program. Be certain that **EVERYONE** operating this machine is familiar with the procedures recommended and follows safety precautions. Remember, most accidents can be prevented. Do not risk injury or death by ignoring good safety practices.

- Read and understand the Operator's Manual and all safety signs before supplying power to, operating, maintaining or adjusting the generator.
- Generator owners must give operating instructions to operators or employees before allowing them to operate the machine, and at least annually thereafter.
- The most important safety device on this equipment is a **SAFE** operator. It is the operator's responsibility to read and understand ALL Safety and Operating instructions in the manual and to follow these. Most accidents can be avoided.
- A person who has not read and understood all operating and safety instructions is not qualified to operate this machine. An untrained operator exposes himself and bystanders to possible serious injury or death.
- Do not modify the equipment in any way. Unauthorized modification may impair the function and/or safety and could affect the life of the equipment.
- The manual comes with the original documentation for the engine and the alternator: we recommend keeping it all in a safe place and have qualified personnel to carry out operations. In case of transfer of equipment ownership, attach all the documentation, as it is an integral part of the product.
- Our customer service and technical assistance department is available to assist you in any way.
- Only use genuine parts in case replacement is required; failure to comply will void your warranty automatically.

## 2.1 GENERAL SAFETY

- Read and understand the Operator's Manual and all safety signs before supplying power to, operating, maintaining or adjusting the generator. 
- Only trained, competent persons shall operate the generator. An untrained operator is not qualified to operate this machine.
- Provide a first-aid kit for use in case of an accident. Store in a highly visible place. 

- Provide a fire extinguisher for use in case of an accident. Store in a highly visible place.
- Install and properly secure all guards and shields before operating. 

- Wear appropriate protective gear. This list includes but is not limited to:
    - Protective shoes with slip resistant soles
    - Protective glasses or goggles
    - Heavy gloves
    - Hearing protection
  - Turn machine OFF, place all controls in their OFF position, shut down and lockout power supply, and wait for all moving parts to stop before servicing, adjusting, maintaining, repairing or cleaning.
  - Do not damage this manual, do not remove or tear any pages and keep it away from moisture and heat sources. Please note that the drawings contained in the manual are merely to help you identify the parts described and, therefore, they might not correspond precisely to your product.
  - Know the emergency medical center number for your area.
  - Review safety related items with all operators annually.
- 

## 2.2 EQUIPMENT SAFETY GUIDELINES

- Safety of the operator and bystanders is one of the main concerns in designing and developing a machine. However, every year many accidents occur which could have been avoided by a few seconds of thought and a more careful approach to handling equipment. You, the operator, can avoid many accidents by observing the following precautions in this section. To avoid personal injury or death, study the following precautions and insist those working with you, or for you, follow them.
- In order to provide a better view, certain photographs or illustrations in this manual may show an assembly with a safety shield removed. However, equipment should never be operated in this condition. Keep all shields in place. If shield removal becomes necessary for repairs, replace the shield prior to use.
- Replace any safety sign or instruction sign that is not readable or is missing. Location of such safety signs is indicated in this manual.
- Never use alcoholic beverages or drugs which can hinder alertness or coordination while operating this equipment. Consult your doctor about operating this machine while taking prescription medications.
- **Under no circumstances should young children be allowed to work with this equipment. Do not allow persons to operate or assemble this unit until they have read this manual and have developed a thorough understanding of the safety precautions and of how it works.** Review the safety instructions with all users annually.
- This equipment is dangerous to children and persons unfamiliar with its operation. The operator should be a responsible, properly trained and physically able person familiar with the machinery and trained in this equipment's operations. If the elderly are assisting with work, their physical limitations need to be recognized and accommodated.
- Never exceed the limits of a piece of machinery. If its ability to do a job, or to do so safely, is in question - **DON'T TRY IT.**
- Do not modify the equipment in any way. Unauthorized modification result in serious injury or death and may impair the function and life of the equipment.
- The contents of this manual are not binding. The manufacturer reserves the right to make changes and improvements to accessories and details without altering the essential characteristics of the model described and illustrated here and without committing to promptly updating this manual.
- In addition to the design and configuration of this implement, including Safety Signs and Safety Equipment, hazard control and accident prevention are dependent upon the awareness, concern, prudence, and proper training of personnel involved in the operation, transport, maintenance, and storage of the machine. Refer also to Safety Messages and operation instruction in each of the appropriate sections of the auxiliary equipment and machine Manuals. Pay close attention to the Safety Signs affixed to the auxiliary equipment and the machine.
- This machine is designed to generate high voltage electrical power that can injure or kill if not operated properly. Read operator's manual and follow all instructions.



## 2.3 SAFETY TRAINING

- Safety is a primary concern in the design and manufacture of our products. Unfortunately, our efforts to provide safe equipment can be wiped out by a single careless act of an operator or bystander.
- In addition to the design and configuration of equipment, hazard control and accident prevention are dependent upon the awareness, concern, prudence and proper training of personnel involved in the operation, transport, maintenance and storage of this equipment.
- It has been said, "The best safety feature is an informed, careful operator." We ask you to be that kind of an operator. It is the operator's responsibility to read and understand ALL Safety and Operating instructions in the manual and to follow these. Accidents can be avoided.
- **Working with unfamiliar equipment can lead to careless injuries. Read this manual, and the manual for your auxiliary equipment, before assembly or operating, to acquaint yourself with the machines. If this machine is used by any person other than yourself. It is the machine owner's responsibility to make certain that the operator, prior to operating:**
  - i. **Reads and understands the operator's manuals.**
  - ii. **Is instructed in safe and proper use.**
- Know your controls and how to stop generators and any other auxiliary equipment quickly in an emergency. Read this manual and the one provided with your other equipment.
- Train all new personnel and review instructions frequently with existing workers. Be certain only a properly trained and physically able person will operate the machinery. A person who has not read and understood all operating and safety instructions is not qualified to operate the machine. An untrained operator exposes himself and bystanders to possible serious injury or death. If the elderly are assisting with work, their physical limitations need to be recognized and accommodated.



## 2.4 SAFETY SIGNS

- Keep safety signs clean and legible at all times.
- Replace safety signs that are missing or have become illegible.
- Replaced parts that displayed a safety sign should also display the current sign.
- Safety signs displayed in Section 3 each have a part number in the lower right-hand corner. Use this part number when ordering replacement parts.
- Safety signs are available from your authorized Distributor or Dealer Parts Department or the factory.

### How to Install Safety Signs:

- Be sure that the installation area is clean and dry.
- Be sure temperature is above 50°F (10°C).
- Determine exact position before you remove the backing paper. (See Section 3).
- Remove the smallest portion of the split backing paper.
- Align the sign over the specified area and carefully press the small portion with the exposed sticky backing in place.
- Slowly peel back the remaining paper and carefully smooth the remaining portion of the sign in place.
- Small air pockets can be pierced with a pin and smoothed out using the piece of sign backing paper.

## 2.5 STORAGE SAFETY

- Store the generator on a firm level surface.
- If required, make sure the unit is firmly blocked up.
- Make certain that all mechanical locks and jacks are safely and positively connected before storing.
- Store away from areas of human activity.
- Do not allow children to play on or around the stored generator.
- Lock out power by turning off master control panel or junction box and padlocking the door shut to prevent electrocution or unauthorized start up of the generator.
- If mounted on a trailer, place chocks in front of and behind the tires before unhooking from tow vehicles.

## 2.6 PREPARATION SAFETY

- Never operate the generator and auxiliary equipment until you have read and completely understand this manual, the auxiliary equipment Operator's Manual, and each of the Safety Messages found on the safety signs on the generator and auxiliary equipment.

- Personal protection equipment including hard hat, safety glasses, safety shoes, and gloves are recommended during assembly, installation, operation, adjustment, maintaining, repairing, or moving the generator. Do not allow long hair, loose fitting clothing or jewelry to be around equipment.



- **PROLONGED EXPOSURE TO LOUD NOISE MAY CAUSE PERMANENT HEARING LOSS!**

Motors or equipment attached can often be noisy enough to cause permanent, partial hearing loss. We recommend that you wear hearing protection on a full-time basis if the noise in the Operator's position exceeds 80db. Noise over 85db on a long-term basis can cause severe hearing loss. Noise over 90db adjacent to the Operator over a long-term basis may cause permanent, total hearing loss. **NOTE:** Hearing loss from loud noise (from tractors, chain saws, radios, and other such sources close to the ear) is cumulative over a lifetime without hope of natural recovery.

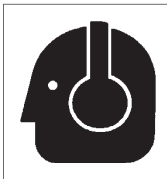

- Clear working area of debris, trash or hidden obstacles that might be hooked or snagged, causing injury, damage or tripping.
- Operate only in daylight or good artificial light.
- Be sure machine is properly anchored, adjusted and in good operating condition.
- Ensure that all safety shielding and safety signs are properly installed and in good condition.
- Before starting, give the machine a "once over" for any loose bolts, worn parts, cracks, leaks, frayed belts and make necessary repairs. Always follow maintenance instructions.

## 2.7 INSTALLATION SAFETY

- Review layout of the worksite. Position generator where it can provide maximum power with minimal interference with the access and operation of other equipment. Select a different position if there is interference.
- Position generator base or trailer on a solid, level surface to avoid tipping, sliding or falls during operation. Avoid placing the unit on a surface with a slope of over 10°.
- Position machine so the engine exhaust is directed away from personnel on the worksite. Direct the gases away from the worksite.
- Use ground terminal inside frame to ground unit in compliance with local laws and regulations.
- Do not operate machine with wet hands or clothing.
- All electrical wires, plugs, sockets and other components must always be in good condition when operating.
- Close and latch the doors during normal operation. Open and latch the doors when the engine is stopped and machine is being serviced.
- Keep engine cooling slots on doors and frame clean to allow engine to cool when running. Clean when trash plugs slots.
- Do not place any items next to exhaust or muffler to prevent burns or items from catching on fire from high temperatures.
- Stop engine and disconnect power if a malfunction occurs. Identify and resolve the malfunction before turning machine on and resuming work.

## 2.8 MAINTENANCE SAFETY

- Read and understand all the information contained in the Operator's Manual regarding operating, servicing, adjusting, maintaining and repairing.
- **Turn machine OFF, shut down and lock out power supply and wait for all moving parts to stop before servicing, adjusting, maintaining or repairing.**
- Follow good shop practices:

- Keep service area clean and dry.
- Be sure electrical outlets and tools are properly grounded.
- Use adequate light for the job at hand.



- Make sure all guards and doors are in place and properly secured when operating the generator.
- Do not work on generator electrical system unless the power cord is unplugged or the power supply is locked out. Lock-out tag-out power source before performing any maintenance work.
- A fire extinguisher and first aid kit should be kept readily accessible while performing maintenance on this equipment.
- Disconnect load from power supply and wait for all moving parts to stop before performing any service or maintenance or work on them.
- Do not touch engine, manifold, pipes and muffler while engine is running. Allow engine to cool before performing any service work on it.
- Always replace guards and shields and close doors when service and repair work has been completed.
- Do not remove radiator cap when engine is running or still hot to prevent leaks and scalding burns.

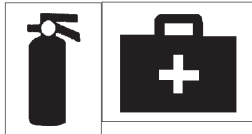

## 2.9 LOCK-OUT TAG-OUT SAFETY

- Establish a formal Lock-Out Tag-Out program for your operation.
- Train all operators and service personnel before allowing them to work around the generator.
- Provide tags at the work site and a sign-up sheet to record tag out details.
- Do not service or maintain the generator unless motor is OFF and the power locked out with the master switch.

## 2.10 BATTERY SAFETY

- Keep all sparks and flames away from batteries, as gas given off by electrolyte is explosive. Always wear gloves.
- Avoid contact with battery electrolyte: wash off any spilled electrolyte immediately.
- Wear safety glasses when working near batteries.
- Do not tip batteries more than 45° to avoid electrolyte loss.
- To avoid injury from spark or short circuit, disconnect battery ground cable before servicing any part of the electrical system.



## 2.11 OPERATING SAFETY

- Read and understand the Operator's Manual and all safety signs before operating, maintaining, adjusting or repairing the generator.
- Turn machine OFF, place master controls in their OFF position shut down and lock out power source, unplug power cord and wait for all moving parts to stop before servicing, adjusting, repairing or unplugging.
- Keep all electrical components tight, dry and in good repair.
- Clear the area of bystanders, especially small children.
- Replace all worn or failed components immediately with **megagen** approved parts.
- Install and secure all guards before operating.
- Keep hands, feet, hair and clothing away from moving parts.
- Review worksite. Position generator to provide electrical power accessibility and minimal interference with other equipment.
- The unit generates sufficient electrical power to injure or kill. Follow appropriate safety procedures.
- Establish a formal Lock-Out/Tag-Out program for your operation and train all operators and service personnel before allowing them work with and around the generator.
- Require all personnel to use Personal Protective Equipment (PPE) when operating or servicing the machine.
- Do not stand or climb on machine when running. Keep others off.
- Keep the working area clean and dry.
- Review safety instructions annually.

## 2.12 TIRE SAFETY

- Failure to follow proper procedures when mounting a tire on a wheel or rim can produce an explosion which may result in serious injury or death.
- Do not attempt to mount a tire unless you have the proper equipment and experience to do the job.
- Have a qualified tire dealer or repair service perform required tire maintenance.
- When replacing worn tires, make sure they meet the original tire specifications. Never under-size.

## 2.13 TRANSPORT SAFETY

- Make certain that you are in compliance with local, state/provincial and federal regulations regarding transporting equipment on public roadways.
- Make certain that all wheels and tires are in good repair and that tires are inflated to proper pressure. Do not under-inflate or over-inflate.
- Make certain that all wheel bolts/lug nuts are tightened to proper torque specifications (refer to specification chart in Section 7.2).
- Secure and lock access doors before transporting.
- Raise jack into its fully UP position and secure with lock pin.
- Do not park generator on a steep slope.
- Be sure that any necessary signs, reflectors and lights required by law are in proper place and are clearly visible to oncoming and overtaking traffic.
- Be sure that the generator is positively hitched to the towing vehicle. Use a safety cable to assure a safe hitch hook-up when transporting.
- Use a 3/4 ton pickup or larger truck to tow machine.
- Do not allow anyone to ride on the generator during transport.
- Clear the area of obstacles and unnecessary personnel.
- Do not place any objects or loads on the frame to prevent changing the center of gravity or overloading the frame.
- Do not exceed a safe travel speed of 90 km/55mph with trailer. Slow down for corners and rough surface conditions.

## 2.14 ELECTRICAL SAFETY

- Use the terminal inside the frame to ground unit in compliance with local laws and regulations.
- All electrical wires, plugs, sockets and other components must always be in good condition when operating.
- Turn master battery and electrical switches off when shutting down unit.
- Do not operate machine with wet hands or clothing.

## 2.15 DIESEL ENGINE SAFETY

**BEFORE STARTING ENGINE, READ AND UNDERSTAND THE OPERATING AND MAINTENANCE INSTRUCTIONS THAT CAME WITH YOUR ENGINE.**

### **WARNING: DO NOT**

- DO NOT run engine in an enclosed area. Exhaust gases contain carbon monoxide, an odorless and deadly poison.
- DO NOT place hands or feet near moving or rotating parts.
- DO NOT store, spill, or use fuel near an open flame, or devices such as a stove, furnace, or water heater which use a pilot light or devices which can create a spark.
- DO NOT refuel indoors where area is not well ventilated. Outdoor refuelling is preferred.
- DO NOT fill fuel tank while engine is running. Allow engine to cool for 5 minutes before refuelling. Store fuel in approved safety containers.
- DO NOT remove fuel tank cap while engine is running.
- DO NOT operate engine if fuel is spilled. Move machine away from the spill and avoid creating any ignition until the fuel has evaporated.
- DO NOT smoke when filling fuel tank.
- Whenever possible, gradually reduce engine speed before stopping.
- DO NOT run engine above rated speeds. This may result in injury.
- DO NOT tamper with parts which may increase the governed engine speed.
- DO NOT tamper with the engine speed selected by the original equipment manufacturer.
- DO NOT strike flywheel with a hard object or metal tool as this may cause flywheel to shatter in operation. Use proper tools to service engine.
- DO NOT operate engine without a muffler. Inspect periodically and replace, if necessary. If engine is equipped with muffler deflector, inspect periodically and replace, if necessary with correct deflector.
- DO NOT operate engine with an accumulation of grass, leaves, dirt or other combustible materials in the muffler area.
- DO NOT use this engine on any forest covered, brush covered, or grass covered unimproved land unless a spark arrester is installed on the muffler. The arrester must be maintained in effective working order by the operator. In the State of California the above is required by law (Section 4442 of the California Public Resources Code). Other states may have similar laws. Federal laws apply on federal lands.
- DO NOT touch hot muffler, cylinder or manifold because contact may cause burns.

- DO NOT run engine with air cleaner or air cleaner cover removed.

### **WARNING: DO**

- ALWAYS Disconnect the battery disconnect switch before servicing engine to prevent accidental starting.
- DO examine muffler periodically to be sure it is functioning effectively. A worn or leaking muffler should be repaired or replaced as necessary.
- DO use fresh fuel. Stale fuel can gum fuel injection system.
- DO check fuel lines and fittings frequently for cracks or leaks. Replace if necessary.

## 2.16 REFUELLING SAFETY

- Handle fuel with care. It is highly flammable.
- Allow engine to cool for 5 minutes before refuelling. Clean up spilled fuel before restarting engine.
- Do not refuel the machine while smoking or when near open flame or sparks.
- Fill fuel tank outdoors.
- Prevent fires by keeping machine clean of accumulated trash, grease and debris.







### 3 SAFETY SIGN LOCATIONS

The types of safety signs and locations on the equipment are shown in the illustrations that follow. Good safety requires that you familiarize yourself with the various Safety Signs, the type of warning and the area, or particular function related to that area, that requires your SAFETY AWARENESS.

• Think SAFETY! Work SAFELY!

#### 3.1 Model x48

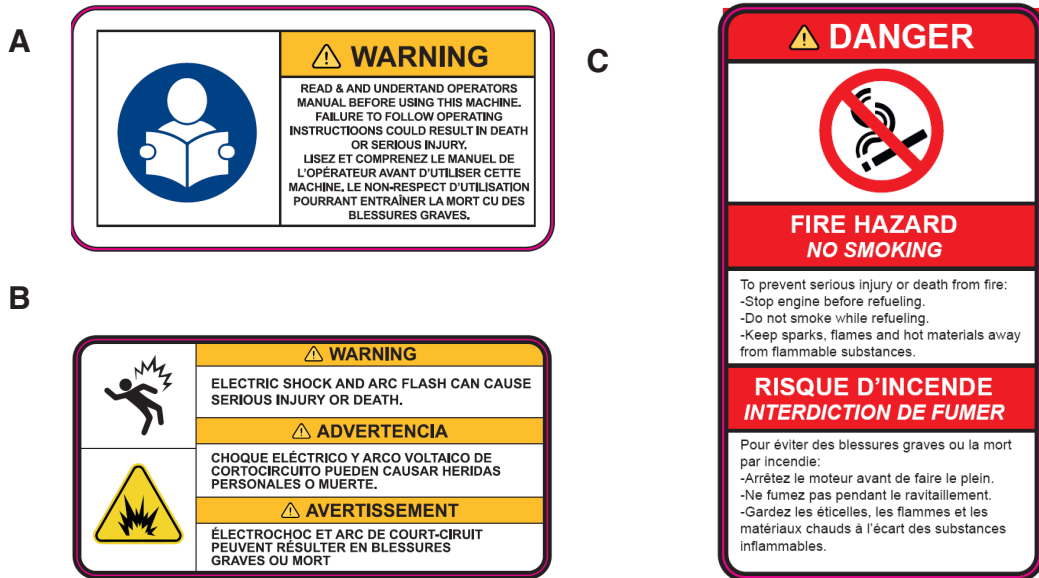

REMEMBER - If Safety Signs have been damaged, removed, become illegible or parts replaced without safety signs, new signs must be applied. New safety signs are available from your authorized dealer. The types of safety signs and locations on the equipment are shown in the illustrations that follow. Good safety requires that you familiarize yourself with the various Safety Signs, the type of warning and the area, or particular function related to that area, that requires your SAFETY AWARENESS.

• Think SAFETY! Work SAFELY!

## 4 OPERATION



### OPERATING SAFETY

- Read and understand the Operator's Manual and all safety signs before operating, maintaining, adjusting or repairing the generator.
- Turn machine OFF, place master controls in their OFF position shut down and lock out power source, unplug power cord and wait for all moving parts to stop before servicing, adjusting, repairing or unplugging.
- Keep all electrical components tight, dry and in good repair.
- Clear the area of bystanders, especially small children.
- Replace all worn or failed components immediately with **megagen** approved parts.
- Install and secure all guards before operating.
- Keep hands, feet, hair and clothing away from moving parts.
- Review worksite. Position generator to provide electrical power accessibility and minimal interference with other equipment.
- The unit generates sufficient electrical power to injure or kill. Follow appropriate safety procedures.
- Establish a formal Lock-Out/Tag-Out program for your operation and train all operators and service personnel before allowing them work with and around the generator.
- Require all personnel to use Personal Protective Equipment (PPE) when operating or servicing the machine.
- Do not stand or climb on machine when running. Keep others off.
- Keep the working area clean and dry.
- Review safety instructions annually.

#### 4.1 TO THE NEW OPERATOR OR OWNER

The **megagen** generator is designed to provide electrical power to areas where the power grid isn't available using a diesel engine as a power source.

**It is the responsibility of the owner or operator to read this manual and to train all other operators before they start working with the machine. In addition to the design and configuration of equipment, hazard control and accident prevention are dependent upon the awareness, concern, and prudence of personnel involved in the operation, transport, maintenance and storage of equipment or in the use of facilities.**

**Follow all safety instructions exactly. Safety is everyone's business. By following recommended procedures, a safe working environment is provided for the operator, bystanders and the area around the worksite. Untrained operators are not qualified to operate the machine.**

Many features incorporated into this machine are the result of suggestions made by customers like you. Read this manual carefully to learn how to operate the machine safely and how to set it to provide maximum efficiency. By following the operating instructions in conjunction with a good maintenance program, your **megagen** generator will provide many years of trouble-free service.

## 4.2 MACHINE COMPONENTS

The megagen generator is a diesel engine powering an alternator to generate electricity. This electricity is used to provide power to equipment or systems that require electric power in remote areas or where connecting to the grid is inconvenient, impossible or not appropriate.

Engine, radiator, muffler, fuel tank, are all mounted inside the frame. Exhaust is direct out the top of the frame and away from the working area. Fittings are provided to attach an auxiliary fuel tank to the unit to provide longer running time between refuelling. The fuel tank is mounted under the engine and convenient to refuel. the alternator is mounted on the flywheel housing to eliminate any drivetrain components.

Batteries inside the frame provide power to start the engine. All controls and electrical connections are on the left side of the frame.

Five connections with breakers are available to connect to 120V, 240V and 480V with various amp loadings and single and 3 phase outputs.

A lift loop is mounted on top of the frame as a convenience to the operator when required.

Slots and a screen on each end of the frame allow air to flow through the frame to cool the engine and other components.

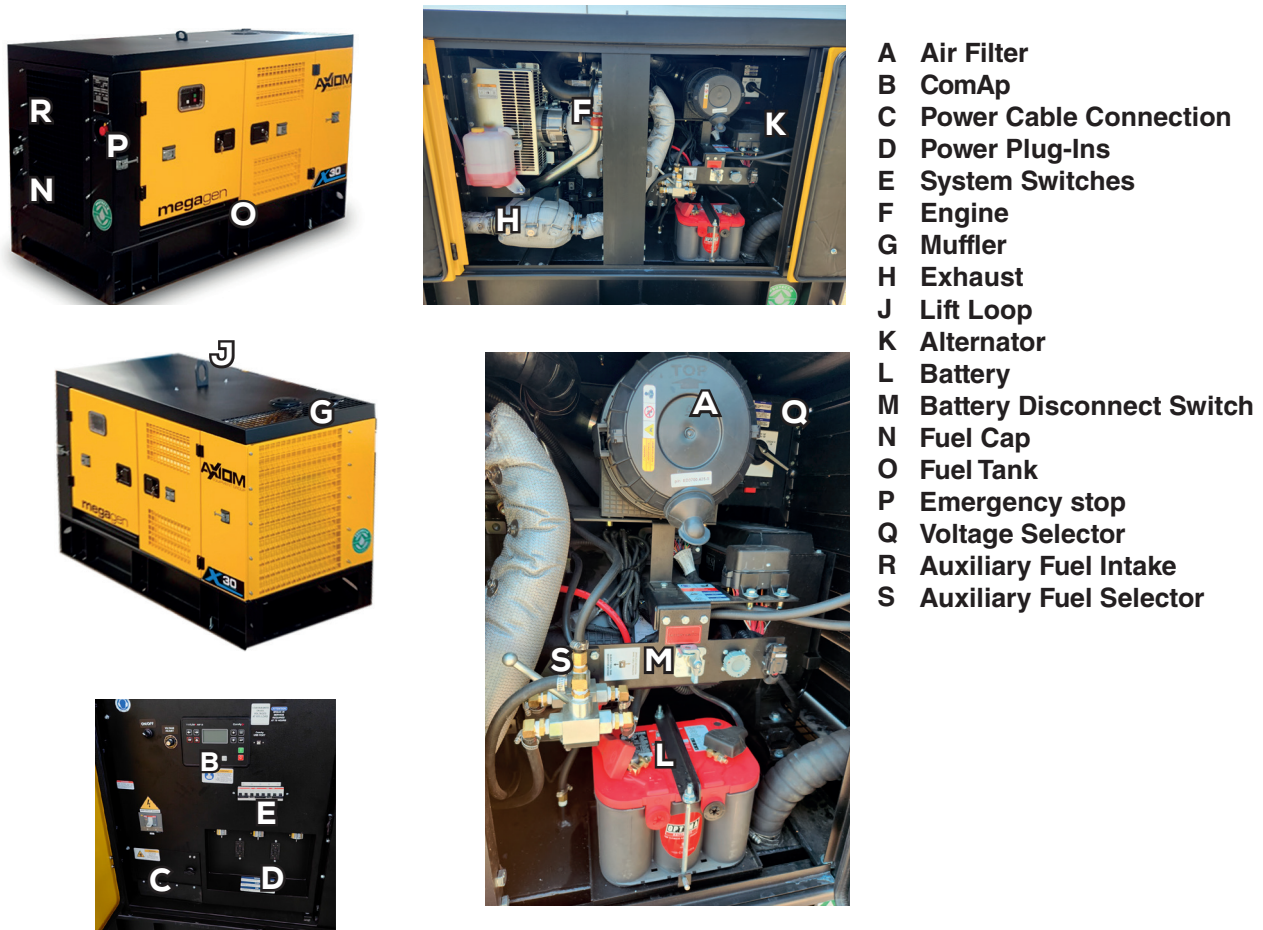

FIG. 1 MACHINE & TANK COMPONENTS (TYPICAL)

### 4.3 MACHINE BREAK-IN

Although there are no operational restrictions on the **megagen** generator when used for the first time, it is recommended that the following mechanical items be checked:

- A. Read all manuals before starting including generator's engine and alternator. Follow break-in procedures.
- B. **After 2, 5 and 10 hours of operation:**
  - 1. Check that all electrical connections are tight and cords are routed out of the way or protected.
  - 2. Clean air flow louvers.
  - 3. Check levels in engine. Top up as required.
- C. **Break in service required at 75 hours:**
  - 1. Drain engine oil and change engine oil filter. Then continue with regular service intervals of every 500 hours
- D. **After 500 hours of operation:**
  - 1. Change the engine oil and oil filter. Replace with recommended oil.
  - 2. Replace fuel screen filter and water trap fuel filter.
  - 3. Then go to regularly scheduled service schedule.

### 4.4 PRE-OPERATION CHECKLIST

Safe and efficient operation of your new generator requires that each operator reads and follows all safety precautions and operating procedures contained in this section. Performing the following pre-operation checklist is important for personal safety as well as for continued mechanical soundness and longevity of your new **megagen** generator. The checklist should be performed before operating the generator and prior to each operation thereafter.

- Insure that proper protective gear is in good repair and available for use by each operator. Make certain that each operator uses the protective gear. Protective gear includes but, is not limited to:



- Gloves
  - Safety glasses or face shield
  - Full length protective clothing
  - Steel toed boots with slip resistant soles.
  - Hearing protection.
- Insure that all safety guards and shields are in good repair and securely in place.
  - Check that frame is level. Adjust as required.
  - Make sure that all electrical switches are in the OFF position before starting engine.
  - Check that all electrical connections are tight and cords are routed out of the way or protected.
  - Be sure the working area is clean and dry to prevent tripping or slipping.



## 4.5 CONTROLS

It is recommended that all operators read the ComAp module manual to learn how to operate and navigate through the module features. Knowledge and understanding of this control module allows the operator to monitor a variety of engine and machine parameters. The module is designed to control all machine functions and parameters.

### 1. Control Unit:

ComAp AMF25 IL4

Always refer to the manual provided with the unit or refer to the unit on line for detailed instructions on setting and operation of unit.

ComAp AMF25 IL4 is an Auto start controller that monitors the unit and indicates operational status and fault conditions. The controller can be programmed to automatically start or stop based on time schedule, fault condition or load demand.

The controller constantly monitors vital generator and engine functions for a number of pre-programmed alarm and fault conditions. When a fault condition occurs, the engine shuts down automatically and the LCD window shows the fault that caused the shutdown. To resume operation, the fault must be corrected. The controller records a history of unit performance, which may be viewed at any time and will not be lost when the controller is powered down.

### 2. Controller:

#### a. Liquid Crystal Display (LCD) Window:

Displays the various operating screens. By viewing these screens, the operator can monitor both the engine and generator status while the unit is running.

#### b. Menu Navigation:

Up/down and left/right arrows are used to navigate through the various operator screens. They are also used to monitor and set the various machine parameters.

#### c. Stop Switch:

Depress to stop if the machine is running on MAN mode.

#### d. Reset switch:

Depress to reset controller or system.

#### e. Programing switch:

Depress to navigate into machine parameters.

#### f. Alarm Mute Switch:

Depress this switch to silence alarms.

#### g. Manual Start Switch:

Depress this switch to initiate the engine start sequence providing there are no shutdown errors, MAN mode is selected and the e-stop switch is released.

#### h. Select Switch:

This switch confirms entries chosen in the various edit menus and screens.

#### i. Main Breaker Switch:

Depress this switch to engage main breakers. If apply.

#### j. Generator Breaker Control:

Depress this switch to engage generator breaker. If apply.

#### k. OFF/ON Switch:

This 2 position rotary switch turns the system control feature OFF or ON.

#### l. Voltage Regulation:

This rheostat is used to adjust and set the generator output voltage by a small amount or fine tune it. Turn clockwise to increase voltage and counterclockwise to decrease.

#### m. USB Port:

This covered USB port is provided to service personnel to use if it is necessary to access or reprogram software for any reason. Covers the port after the work is completed to prevent dirt from entering the port.

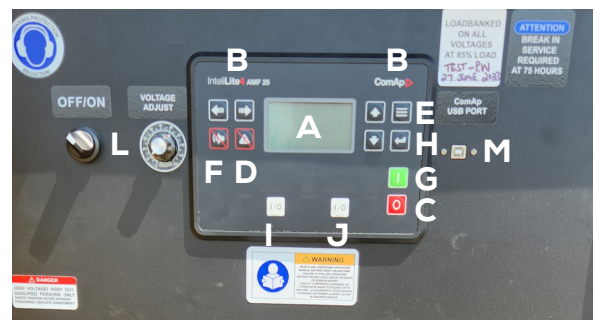

FIG. 2 ComAp AMF25 IL4 CONTROLLER

For further information please refer to ComAp AMF25 IL4 available on <https://www.comap-control.com/products/controllers/single-gen-set-controllers/intelilite/intelilite-4-amf-25/>

**3. Red Emergency Stop:**

This red switch is connected to a micro switch that sends a signal to the controller to shut down the engine. Depress switch and the machine will stop. Turn the switch 1/4 turn to release the switch and it will pop out and the unit can operate. Switch must be out for unit to run. If switch was depressed due to an emergency or condition, correct condition before resuming work.

**4. Main breaker:**

This switch controls the AC power output to the lugs.

**5. Curb Side Engine Door- Battery Disconnect:**

This 2 position rotary switch controls the electrical power to the engine operating system. Turn the switch clockwise to turn the system ON. Turn the switch 1/4 turn counterclockwise to turn power to the engine operating system OFF. Always turn the engine system off when the unit is stopped for the day, being serviced, stored or transported.

**6. Power Outlet Receptacles:**

The generator is equipped with 4 convenience receptacles to provide power for customers. Each outlet is designed with a circuit breaker to prevent overloading. The 120V 20A outlets are standard 3 prong receptacles. The 120V/240V 50A receptacles are the standard twist lock receptacles.

a. 120V 20A.

b. 120V/240V.

**7. Engine Block Heater:**

Connect the cord to the block heater if needed.



**FIG. 3 CONTROL PANEL**

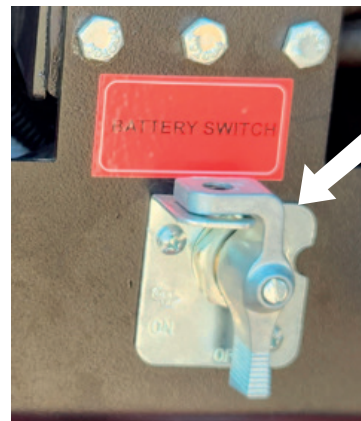

**FIG. 4 MASTER BATTERY DISCONNECT**

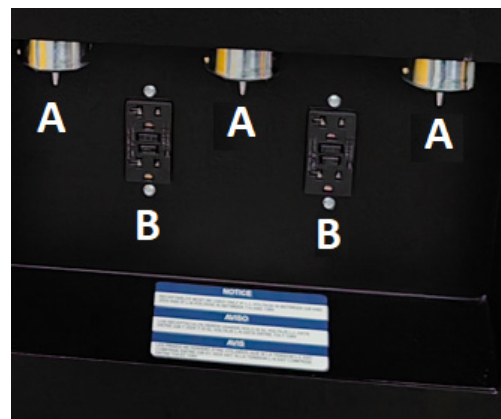

**FIG. 5 OUTLETS**



## 9. Cable Outlets:

### a. L1, L2 and L3:

Circuits L1, L2 and L3 are designed to provide power to cables that are inserted from the bottom of the frame and secured with screw clamps.

### b. N:

Use this connection as a ground for the 'L' circuits.

### c. Ground:

This is the earth ground for the generator. Always connect this circuit to earth ground to eliminate any stray currents.

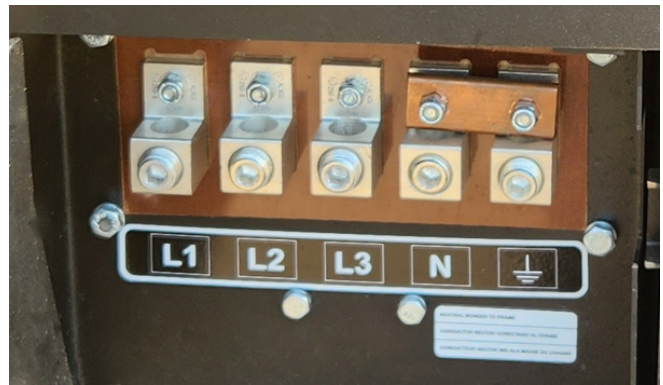

FIG. 6 CABLES

## 10. Rear Compartment:

### a. Voltage Selector:

This 3 position rotary switch selects the generator output voltage and phase output. The options are:

- 277/480V 3 phase
- 208/240V 3 phase or 120/139V Single phase
- 120/240V Single phase



FIG. 7 SWITCHES

## 11. Fuel Tank Selector:

This 2 position valve selects which fuel tank will be used for the engine: internal or external. Move the handle toward the right to draw from the internal and to the left to draw from the external fuel source using the external fuel connectors.

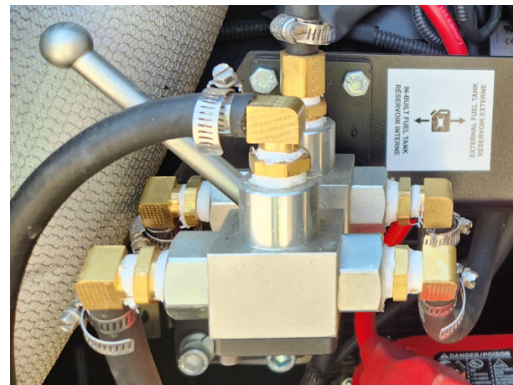



FIG. 8 FUEL TANK SELECTOR

## 4.6 MACHINE PREPARATION

### 4.6.1 MECHANICAL PREPARATION:

#### 1. Batteries:

Batteries are an integral component in the successful operation of the generator and must be kept in top condition for the unit to perform as designed. A starter battery is provided when the unit is new and is used to start the engine

- a. Connect the cable to the battery terminal before starting the generator set. 
- b. Tighten battery pole clamp to its specified torque.
- c. Check the battery isolator if unit is equipped with one.
- d. Use rubber gloves when working with batteries as they contain sulphuric acid. Always rinse with large amounts of fresh water if contacting battery acid to prevent acid burns. It is recommended that the cable be disconnected from the battery prior to transporting the unit.

#### 2. Engine Oil:

It is recommended that the engine oil level be checked daily to prevent running low and damaging the engine. Refer to engine operator's manual for detailed instructions and information on oil specification for varying operating environments. Do not overfill crankcase. 

#### 3. Air Filter:

Check the air filter canister when the unit is new to verify it has a filter installed. Squeeze the rubber flapper valve daily to remove any dirt that has accumulated. Open canister and remove filter if it is dirty. When operating in dusty dirty conditions, it may be necessary to clean the filter every few days. Replace filter after it has been cleaned 4 or 5 times. Do not overclean. Removing and installing the filter can damage seals. Damaged seals can allow dust to enter the engine and damage it. 

#### 4. Diesel Fuel:

Check the fuel level every day to prevent running out. The unit can run up to 30 hours without refueling @75% engine load. 

Turn engine off before refuelling. Do not smoke when refuelling and keep all sparks and burning material away. Refuel outside or in a well ventilated environment. Do not spill fuel. Clean it up before starting. Refer to engine manual for details on types of fuel to use in various temperature environments. Do not overfill tank. Leave 10 mm (1/2 inch) of space between level of fuel and top of tank to allow for fuel expansion. Use winter diesel or add special additives to fuel when operating in cold temperatures.

#### 5. Antifreeze/Coolant:

When the engine is new, it is filled with an anti-freeze solution that is rated to -40° C. The anti-freeze prevents both interior corrosion and protection against freezing. To maintain this protection, do not mix different types of antifreeze. Refer to engine operator's manual to determine the specifications of the approved antifreeze. 

If the cooling system requires servicing, do not remove radiator cap when the engine is running or is still hot as the coolant could spill out abruptly and cause serious burns. Remove cap slowly and carefully. Always maintain the integrity of the coolant overflow tank. It receives the excess coolant as the system heats up and expands. It provides coolant into the radiator as the system cools and contracts.

#### 4.6.2 HANDLING:

The machine is designed with features that allow it to be easily and conveniently moved, positioned and transported.

Three features are available to assist in handling:

1. **Lifting with hoist:**

A bracket on the top of the machine is positioned at the machine centre of gravity. This allows for a hoist to raise the unit without the frame tilting. Attach the hook on the hoist to the centre slot for the best results.

2. **Tie Downs:**

The frame is designed with slots on the bottom of the frame for use to secure to frame when transporting on a trailer. Do not attach to any other place to tie down unit when transporting.



FIG. 9 LIFTING

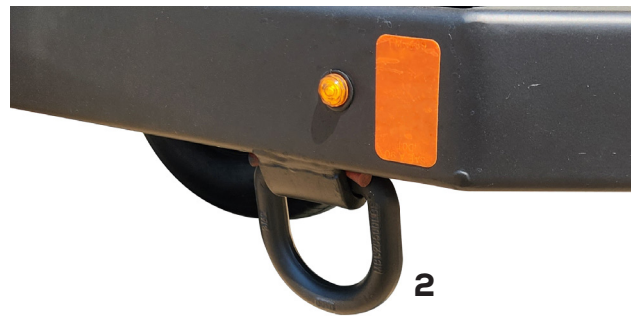

FIG. 10 TRAILER MOUNTING TYPICAL

### 4.6.3 ELECTRICAL PREPARATION:

Every operator should review the operator's manuals from the engine, ComAp and alternator manufacturers provided in the document package. Follow the detailed instructions in each manual:

Connect the neutral point of the generator set to the machine ground. By using the TN or TT distribution system. If complex systems are connected to the machine which require or use additional electrical protective devices you must check the coordination between the protective devices. Use the prepared terminal to earth. Comply with local and/or current regulations on installation and electrical safety.

### 4.6.4 POSITIONING:

Machine positioning and placement are important to the functioning and reliability of the generator.

When positioning machine, follow this procedure:

1. Review the worksite and select an area where the machine is out of the way and not interfere with the other equipment on the worksite and yet provide power to the required area.
2. Tow the machine to the selected spot (Refer to Transport Section) if mounted on a trailer.
3. Unhook from the tow vehicle.
4. Use a crane on hoist to lift generator off transport vehicle and place on ground.
5. Place chocks in front and behind tires.

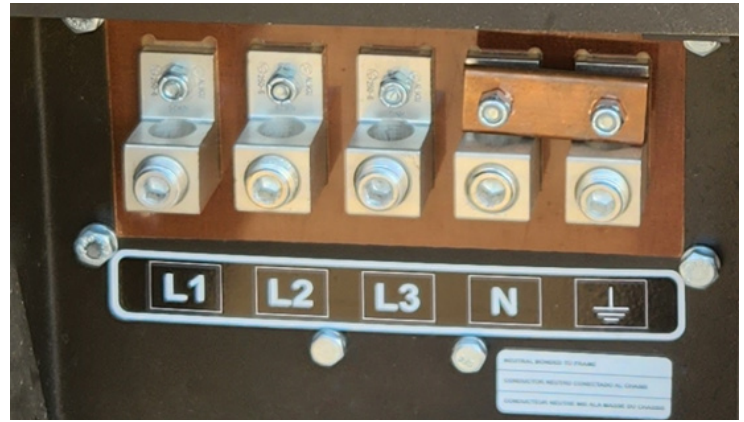

FIG. 11 GROUND TERMINALS



FIG. 12a POSITIONED (TYPICAL)



FIG. 13 CHOCKS (TYPICAL)



#### 4.6.5 ComAp AMF25 LI4

The machine can be upgraded with the ComAp Gateway system used in conjunction with supported ComAp controllers to provide monitoring and communication via the WebSupervisor communication system. The DSEWebNet Gateway communicates to a controller monitoring the instrumentation and operating state.

When this data changes, the new data is logged in the internal memory. At regular intervals the logged data is transmitted to the ComAp hosted server. The ComAp hosted server is then integrated into the WebSupervisor which can be accessed via an internet connected device and web browser to allow remote monitoring and control of ComAp controllers worldwide. GSM, GPS and combined GSM & GPS Antenna's are optional on your x48 generator.

You can easily download installation instruction from: <https://www.comap-control.com/products/software-tools/monitoring-tools/>

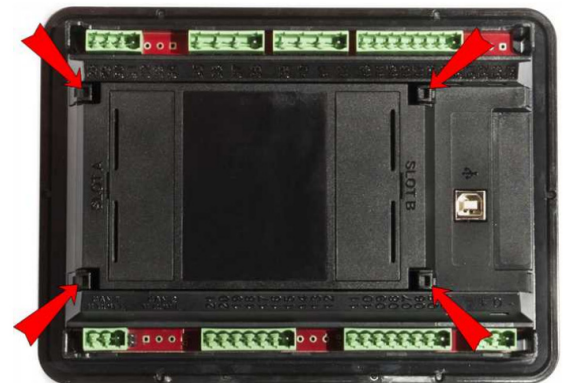
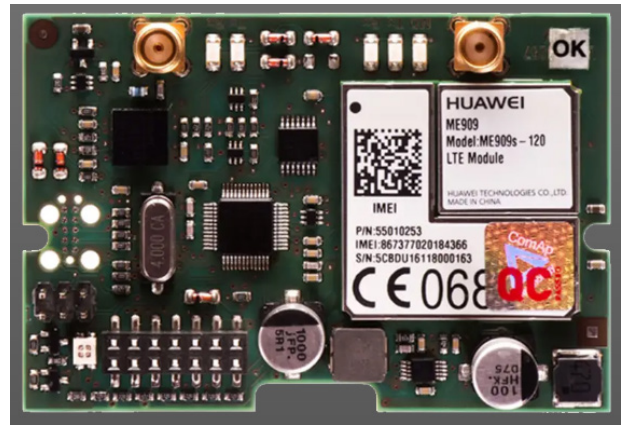

## 4.7 OPERATION



# OPERATING SAFETY

- Read and understand the Operator's Manual and all safety signs before operating, maintaining, adjusting or repairing the generator.
- Turn machine OFF, place master controls in their OFF position shut down and lock out power source, unplug power cord and wait for all moving parts to stop before servicing, adjusting, repairing or unplugging.
- Keep all electrical components tight, dry and in good repair.
- Clear the area of bystanders, especially small children.
- Replace all worn or failed components immediately with **megagen** approved parts.
- Install and secure all guards before operating.
- Keep hands, feet, hair and clothing away from moving parts.
- Review worksite. Position generator to provide electrical power accessibility and minimal interference with other equipment.
- The unit generates sufficient electrical power to injure or kill. Follow appropriate safety procedures.
- Establish a formal Lock-Out/Tag-Out program for your operation and train all operators and service personnel before allowing them work with and around the generator.
- Require all personnel to use Personal Protective Equipment (PPE) when operating or servicing the machine.
- Do not stand or climb on machine when running. Keep others off.
- Keep the working area clean and dry.
- Review safety instructions annually.

Follow this procedure when using the generator:

1. Move unit to work site and unhook or unload (refer to Transport Section).



FIG. 14 MACHINE (TYPICAL)

2. Chock the wheels if mounted on trailer.
3. Review Section 4.6 Machine Preparation and follow all the instructions.
3. Review and follow the pre-operation checklist (See Section 4.4).
4. Review the location and function of all controls (See Section 4.5).



FIG. 15 CHOCKS (TYPICAL)



5. **Starting Steps:**

- a. Refer to and follow the machine preparation and set-up sections. Be sure machine is located on a firm, level base.
- b. Release the red e-stop switch by turning it 1/4 turn.

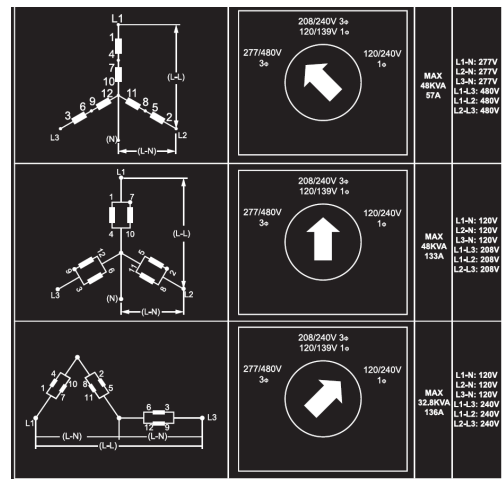

**FIG. 16 EMERGENCY STOP**

- c. Use the selector switch to select the voltage and phase of the generator output desired.



- d. Review the terminal connection specifications and select the appropriate terminal.



**FIG. 17 OUTPUT SELECTORS - X48 (TYPICAL)**

g. Turn the battery isolator switch ON.

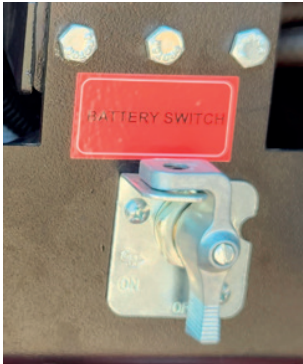

FIG. 18 ISOLATOR SWITCH

- h. Depress horizontal arrows to set "MAN" mode.
- i. Depress the green engine start switch to initiate the engine start sequence.
- j. Wait until the engine stabilizes.
- k. Set voltage with potentiometer to desired voltage.



- l. Turn circuit breaker "ON" once all the counters on screen have finished, and the "No Timer" leyend on main screen apears.

FIG. 19 NO LOAD

**11. Fuel Tank Selector:**

The generator is designed with an internal fuel tank that comes from the factory and is plumbed into the engine. In addition a set of fuel connections are provided on the left side of the frame that allow the operator to connect an auxiliary tank to provide longer operating time between refuelling. Use the handle on the selector valve as an indicator on which tank is being used:

- a. Selector valve - Internal.
- b. Auxiliary tank couplers.

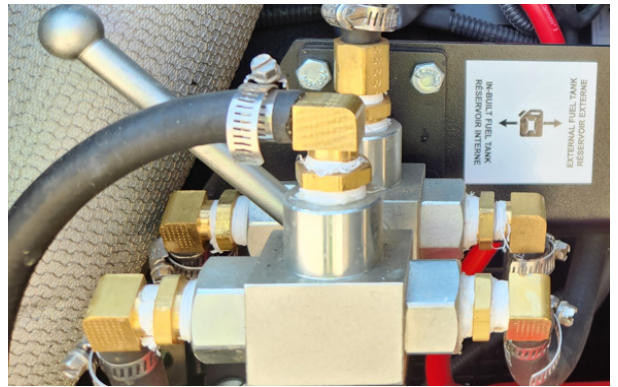

**Selector Valve - Internal**



**FIG. 20 FUEL SYSTEM**

## 11. Operating Hints:

- a. The machine is designed to generate a large amount of electrical power that can injure, maim and kill if not handled with care.
  - Always stop engine, place all controls in their off position and wait for all moving parts to stop before servicing, maintaining, adjusting or cleaning machine.
  - Always use Personal protective Equipment (PPE) when operating or servicing machine.
- b. Keep the area around the machine clean and free from clutter to prevent ripping or slipping.

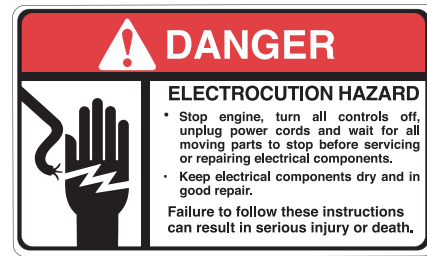

FIG. 23 CLEAN WORKING AREA

- c. Always attach doors to latch anchor behind the door when it has been opened to prevent closing from a gust of wind.

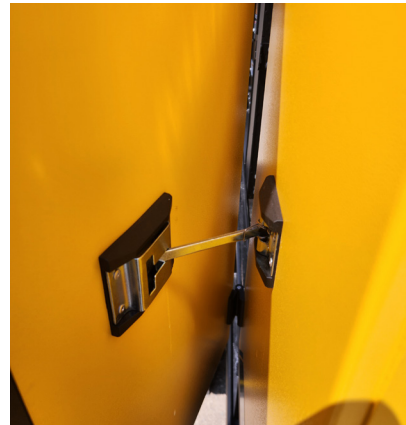

FIG. 24 DOOR LATCH

## 4.8 STORAGE



### STORAGE SAFETY

- Store the generator on a firm level surface.
- If required, make sure the unit is firmly blocked up.
- Make certain that all mechanical locks and jacks are safely and positively connected before storing.
- Store away from areas of human activity.
- Do not allow children to play on or around the stored generator.
- Lock out power by turning off master control panel or junction box and padlocking the door shut to prevent electrocution or unauthorized start up of the generator.
- If mounted on a trailer, place chocks in front of and behind the tires before unhooking from tow vehicles.

### 4.8.1 PLACING IN STORAGE

At the end of the season, the machine should be thoroughly inspected and prepared for storage. Repair or replace any worn or damaged components to prevent any unnecessary down time at the beginning of the next season. Follow this procedure:

- Start the engine and run for 10 minutes to bring the oil to operating temperature. Change the oil and oil filter. Replace the engine oil as specified in the Maintenance Section.
- Thoroughly wash the outside of the machine using a pressure washer to remove all dirt, mud, debris or residue.
- Do not wash the inside of the machine to prevent getting water into the alternator and electrical circuits.
- If stored on an **megagen** trailer, lower hitch jack and secure.
- Place chocks in front of and behind wheels if mounted on trailer.
- Press the red switch on the ComAp controller to turn engine OFF.
- Turn main battery disconnect OFF.
- Touch up all paint nicks and scratches to prevent rusting.
- Select a storage area that is dry, level and free of debris.

### 4.8.2 REMOVING FROM STORAGE

When preparing to use the machine at the start of the season, follow this procedure:

- Transport or move to the working area.
- Check
  - a. Engine fluid levels.
  - b. Electrical systems and components.
  - c. All hardware. Tighten as required.
  - e. Air pressure in tires. Add as required.
- Replace any defective components.
- Go through the pre-operation checklist (section 4.4) before starting.



FIG. 25 STORED (TYPICAL)



## 4.9 TRANSPORT



# TRANSPORT SAFETY

- Make certain that you are in compliance with local, state/provincial and federal regulations regarding transporting equipment on public roadways.
- Make certain that all wheels and tires are in good repair and that tires are inflated to proper pressure. Do not under-inflate or over-inflate.
- Make certain that all wheel bolts/lug nuts are tightened to proper torque specifications (refer to specification chart in Section 7.2).
- Secure and lock access doors before transporting.
- Raise jack into its fully UP position and secure with lock pin.
- Do not park generator on a steep slope.
- Be sure that any necessary signs, reflectors and lights required by law are in proper place and are clearly visible to oncoming and overtaking traffic.
- Be sure that the generator is positively hitched to the towing vehicle. Use a safety cable to assure a safe hitch hook-up when transporting.
- Use a 3/4 ton pickup or larger truck to tow machine.
- Do not allow anyone to ride on the generator during transport.
- Clear the area of obstacles and unnecessary personnel.
- Do not place any objects or loads on the frame to prevent changing the center of gravity or overloading the frame.
- Do not exceed a safe travel speed of 90 km/55mph with trailer. Slow down for corners and rough surface conditions.

**megagen** X48 generator is designed and equipped to be towed on public roadways when mounted on an **megagen** trailer by vehicles with sufficient weight and braking capability. If not mounted on trailer, they must be loaded on a transport trailer and hauled.

Prepare the unit by:

- Press the red switch on the Comap controller to turn engine OFF and turn key switch OFF.
  - Turn main battery disconnect OFF.
  - Remove any cords plugged into the machine.
  - Hook up to tow unit.
- a. Align hitches while backing up to hitch.
  - b. Connect pintle or ball hitch.
  - c. Secure hitch with retainer to prevent unexpected separation.



**Aligning**



**Retainer**

**FIG. 26 PINTLE HITCH**



d. Attach safety chains while crossing them under the hitch.



**Safety Chain - Attached**

e. Attach wiring harness terminal.



**Wiring Harness - Connected**

f. Raise the hitch jack into its fully UP position.

g. Rotate jack and pin in its horizontal position.

h. Secure jack handle with its retainer.

i. Reverse this procedure when unhooking.



**Jack Rotated/Handle Secured**

- Check that all required lights are clean and no bulbs are burned out.
- Do not drink or use drugs and drive.
- Do not allow riders on machine.
- Do not exceed a safe travel speed. Slow down for corners or rough surfaces.



**Hooked Up**

**FIG. 27 TRANSPORTING**

## 5 SERVICE AND MAINTENANCE



### MAINTENANCE SAFETY

- Read and understand all the information contained in the Operator's Manual regarding operating, servicing, adjusting, maintaining and repairing.
- **Turn machine OFF, shut down and lock out power supply and wait for all moving parts to stop before servicing, adjusting, maintaining or repairing.**
- Follow good shop practices:
  - Keep service area clean and dry.
  - Be sure electrical outlets and tools are properly grounded.
  - Use adequate light for the job at hand.
- Make sure all guards and doors are in place and properly secured when operating the generator.
- Do not work on generator electrical system unless the power cord is unplugged or the power supply is locked out. Lock-out tag-out power source before performing any maintenance work.
- A fire extinguisher and first aid kit should be kept readily accessible while performing maintenance on this equipment.
- Disconnect load from power supply and wait for all moving parts to stop before performing any service or maintenance or work on them.
- Do not touch engine, manifold, pipes and muffler while engine is running. Allow engine to cool before performing any service work on it.
- Always replace guards and shields and close doors when service and repair work has been completed.
- Do not remove radiator cap when engine is running or still hot to prevent leaks and scalding burns.

## 5.1 SERVICE

### 5.1.1 FLUIDS AND LUBRICANTS

1. **Grease:**  
Use an SAE multipurpose high temperature grease with extreme pressure (EP) performance. Also acceptable is an SAE multipurpose lithium base grease.
2. **Engine Oil:**  
Refer to engine manual for oil specifications to use with this engine. Consult the engine manual for unusual operating conditions. Do not mix oil types or viscosities.  
  
Refer to engine manual for oil specifications
3. **Diesel Fuel:**  
Refer to engine manual for fuel specifications. Special fuel and additives required for cold ambients.
4. **Storing Lubricants:**  
Your machine can operate at top efficiency only if clean lubricants are used. Use clean containers to handle all lubricants. Store them in an area protected from dust, moisture and other contaminants.

## 5.1.2 SERVICING INTERVALS

### 8 Hours or Daily

1. Check engine fluid levels:
  - a. Fuel
  - b. Crankcase oil
  - c. Coolant



Fuel Cap

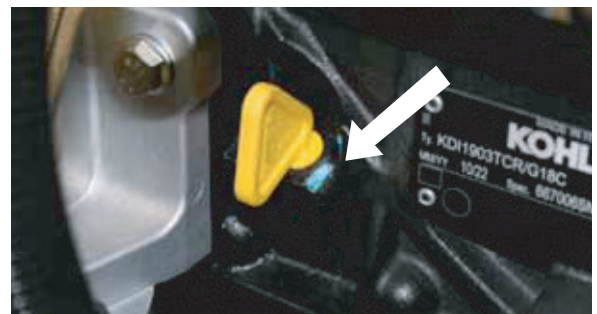

Dipstick



Coolant

FIG. 28 FLUID LEVELS

2. Remove dust from air cleaner flapper.

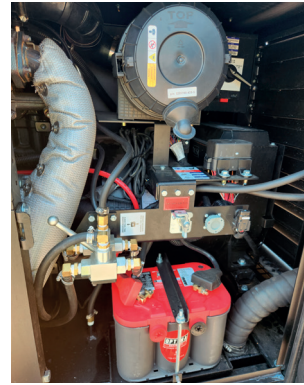

**FIG. 30 AIR CLEANER**

3. Clean air louvers.



**In**



**Out**

**FIG. 31 SCREENS**



## 100 Hours

1. Change break-in engine oil and oil filter. This service item only must be done once when unit is new. Then service every 500 hours. Follow the service schedule outlined in the engine manufacturer's manual.

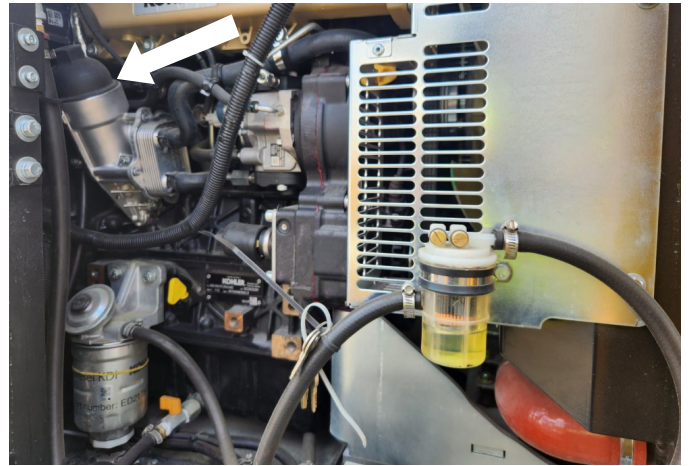

**FIG. 32 OIL FILTER**

## As Required

1. Remove the air cleaner filter and shake it out. Replace filter after cleaning 5 times.

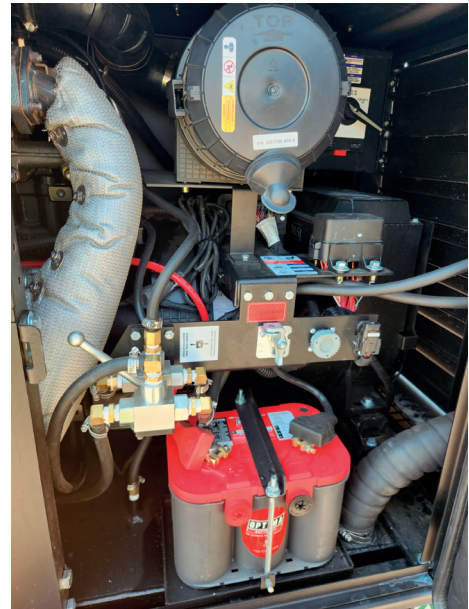

**FIG. 33 AIR CLEANER (TYPICAL)**

## **500 Hours or Annually**

1. Change:
  - a. Oil
  - b. Oil filter
  - c. Fuel pre-screen filter
  - d. Fuel filter
  - e. Air filter  
Done on a 1000Hr service.  
Replace if needed at 500Hrs
2. Clean machine.

### **IMPORTANT**

Never pressure wash near the alternator end as it may cause electrocution or catastrophic failure of major components.





## **5.2 MAINTENANCE**

The machine is designed to generate electricity for use at any location for any purpose. By following a careful service and maintenance program on your machine, you will enjoy many years of trouble-free use.

### **5.2.1 ELECTRIC SYSTEM INSPECTION**

To maintain the integrity of each system and provide a safe working environment for the operator, it is important that a daily inspection be done to make sure that all systems and components are in good working condition.

When inspecting the electrical system and components, follow this procedure:

1. Place all controls in the OFF or neutral position.
2. Turn master electric switch OFF and lockout before starting the inspection.
3. Inspect all electrical components looking for:
  - a. Damaged outlets.
  - b. Frayed or loose wires.
  - c. Cut or cracked insulation.
4. Replace any damaged components immediately. Work to be performed by a trained and competent electrician.
5. Be sure all components are grounded.
6. Be sure there is not water or moisture in any junction box or enclosure. Dry the components before turning power on. Be sure that all compartments seal properly when closed.

## 5.2.2 CLEANING AIR CLEANER

1. Review the operator's manual for the engine.
2. Place all controls in the OFF or neutral position.
3. Turn OFF battery disconnect.
4. Open engine door.
5. Remove cover over air cleaner.
6. Remove the filter from the air cleaner.
7. Use a damp cloth to remove any dust and debris from the filter housing. Shake the dust and dirt out of the filter.
8. Install filter. Replace filter if needed.
9. Install and secure cover.
10. Close and secure engine door.

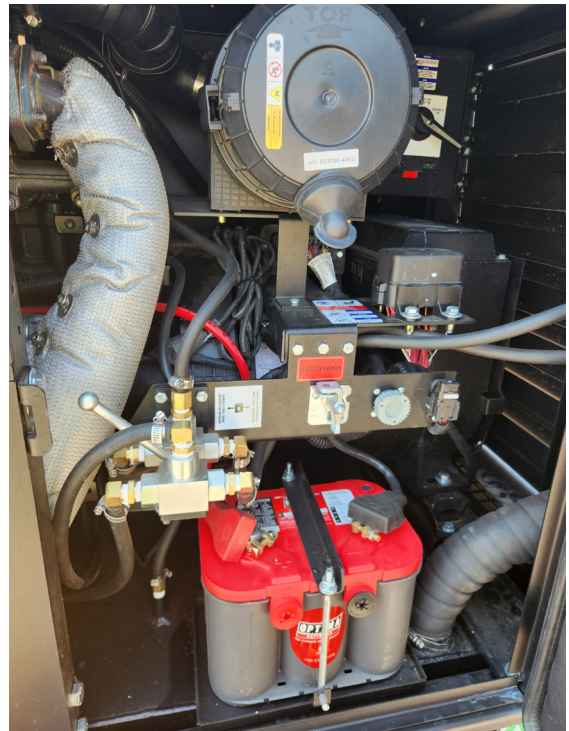

**FIG. 36 AIR CLEANER (TYPICAL)**

### 5.2.3 CHANGING ENGINE OIL AND FILTER

1. Review the manual for the engine.
2. Place all controls in the OFF or neutral position.
3. Turn OFF battery disconnect.
4. Open engine door.
5. Allow the engine to cool before changing the oil. Hot oil can cause burns if it contacts exposed skin. It is best to change oil while the engine is warm to keep any contaminants in suspension.
6. Place a pan under the oil discharge hose.
7. Open drain valve and let drain until all oil is drained.
8. Remove the engine oil filter housing cap to change oil filter. Replace O-ring on oil filter cap.
9. Apply a light coat of oil to the 'O' ring and install the replacement filter. Snug up by hand and then tighten to correct torque.
10. Close the drain valve and secure the drain hose.
11. Dispose of the used oil in an approved container at a disposal site.
12. Fill the crankcase with specified oil.
13. Run the engine for 1 - 2 minutes and check for oil leaks.
14. If leaks are found around the drain plug or filter, tighten slightly.
15. Check engine oil level. Top up as required.
16. Close and secure engine access door.



**Dipstick**

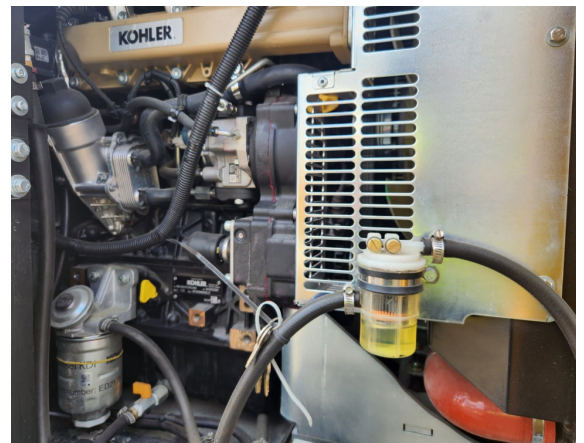

**Oil Filter**

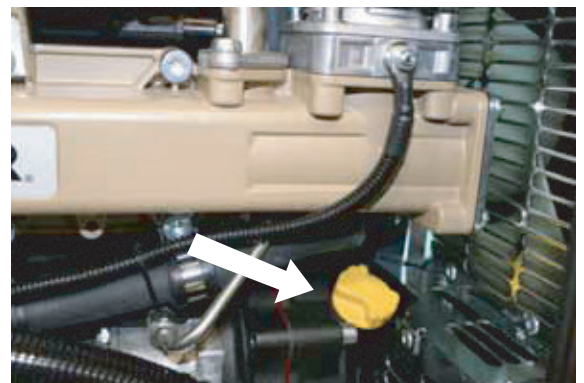

**Fill Cap**

**FIG. 37 ENGINE**

## 5.2.4 CHANGING ENGINE FUEL FILTER AND WATER TRAP SCREEN FILTER

1. Review the operator's manual for the engine.
2. Place all controls in the OFF or neutral position.
3. Turn OFF battery disconnect.
4. Open engine door.
5. Allow the engine to cool before changing the fuel filter. Hot fuel can cause burns if it contacts exposed skin.
6. Place a pan under the fuel filter.
7. Loosen the hose clamps and remove fuel hoses from screen filter.
8. Remove and replace screen filter.
9. Fit fuel hoses to screen filter and tighten hose clamps.
10. To replace water trap fuel filter, disconnect water trap sensor.
11. Loosen filter.
12. Drain fuel from filter into a container.
13. Dispose of fuel in an environmentally safe manner.
14. Remove water trap sensor from old filter.
15. Remove old O-ring and fit new one on sensor.
16. Install water trap sensor onto new filter.

### **IMPORTANT**

NEVER PRE-FILL fuel/water trap before installation as this may cause damage to the fuel injection system. Prime fuel filter using the prime valve on the fuel filter housing until pressure is felt on the prime button/pump.

17. Check engine fuel level. Top up as required.
18. Close and secure engine access door.

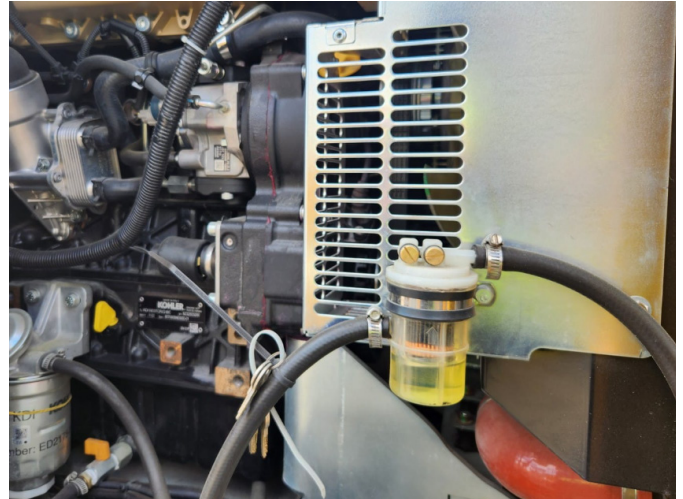

**FIG. 38 ENGINE FUEL FILTER**



## 6 TROUBLE SHOOTING

The **megagen** x48 generator is a machine with an alternator and controls to generate single or 3 phase power at 3 different power levels. A diesel engine provides power to generate electricity

In the following section, we have listed many of the problems, causes and solutions to the problems that you may encounter.

If you encounter a problem that is difficult to solve, even after having read through this trouble shooting section, please contact your local **megagen** dealer or the factory. Before you call, please have this Operator's Manual from your machine ready.

<b>PROBLEM</b>	<b>CAUSE</b>	<b>SOLUTION</b>
Engine won't start.	Low battery.	Charge battery.
	Emergency STOP switch engaged.	Release STOP switch.
Start and stop (engine).	No fuel.	Fill fuel tank. Bleed fuel lines.
	Clogged fuel filter.	Replace fuel filter.
	Fuel circuit failure.	Check fuel lines.
No generator output.	Main circuit breaker open.	Close main circuit breaker.
	Voltage regulator malfunction.	Call <b>megagen</b> main for service.
Low oil pressure.	Low oil level.	Fill engine sump with oil.
	Clogged oil filter.	Replace oil filter.
	Oil pump failure.	Call <b>megagen</b> main for service.
High coolant temperature.	Electrical overload.	Reduce load.
	Low coolant level.	Fill with coolant.
	Low oil level.	Fill sump with oil.
	Clogged oil filter.	Call <b>megagen</b> main for service.

## 7 SPECIFICATIONS

### 7.1 MECHANICAL

The X48 generator that can provide electrical power at any location. Please see data sheet below and dimensional specifications as well.

<b>SPECIFICATIONS</b>		<b>x48</b>
<b>Engine</b>		<b>Kohler KDI2504TCR</b>
<b>Gen End</b>		<b>WEG</b>
<b>Prime Output</b>	<b>kW (kVA)</b>	<b>34.5 (43.2)</b>
<b>Trailer Option</b>		<b>Yes</b>
<b>Voltage</b>	<b>V</b>	<b>240 / 480</b>
<b>Secondary Fluid Containment</b>		<b>110%</b>

**SPECIFICATIONS SUBJECT TO CHANGE WITHOUT NOTICE**

## 7.2 BOLT TORQUE

### CHECKING BOLT TORQUE

The tables shown below give correct torque values for various bolts and capscrews. Tighten all bolts to the torques specified in chart unless otherwise noted. Check tightness of bolts periodically, using bolt torque chart as a guide. Replace hardware with the same strength bolt.

### ENGLISH TORQUE SPECIFICATIONS

Bolt Diameter "A"	Bolt Torque*					
	SAE 2 (N.m) (lb-ft)		SAE 5 (N.m) (lb-ft)		SAE 8 (N.m) (lb-ft)	
1/4"	8	6	12	9	17	12
5/16"	13	10	25	19	36	27
3/8"	27	20	45	33	63	45
7/16"	41	30	72	53	100	75
1/2"	61	45	110	80	155	115
9/16"	95	60	155	115	220	165
5/8"	128	95	215	160	305	220
3/4"	225	165	390	290	540	400
7/8"	230	170	570	420	880	650
1"	345	225	850	630	1320	970

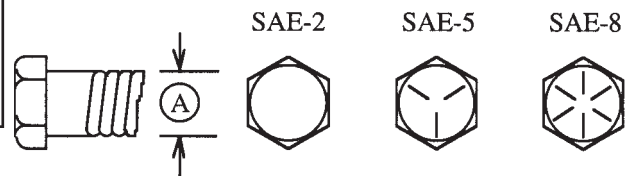

### METRIC TORQUE SPECIFICATIONS

Bolt Diameter "A"	Bolt Torque*			
	8.8 (N.m) (lb-ft)		10.9 (N.m) (lb-ft)	
M3	.5	.4	1.8	1.3
M4	3	2.2	4.5	3.3
M5	6	4	9	7
M6	10	7	15	11
M8	25	18	35	26
M10	50	37	70	52
M12	90	66	125	92
M14	140	103	200	148
M16	225	166	310	229
M20	435	321	610	450
M24	750	553	1050	774
M30	1495	1103	575	1550
M36	2600	1917	3675	2710

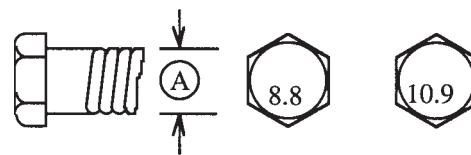

Torque figures indicated above are valid for non-greased or non-oiled threads and heads unless otherwise specified. Therefore, do not grease or oil bolts or capscrews unless otherwise specified in this manual. When using locking elements, increase torque values by 5%.

\* Torque value for bolts and capscrews are identified by their head markings.

# 7.3 ELECTRICAL SCHEMATIC

## Control panel wiring page 1

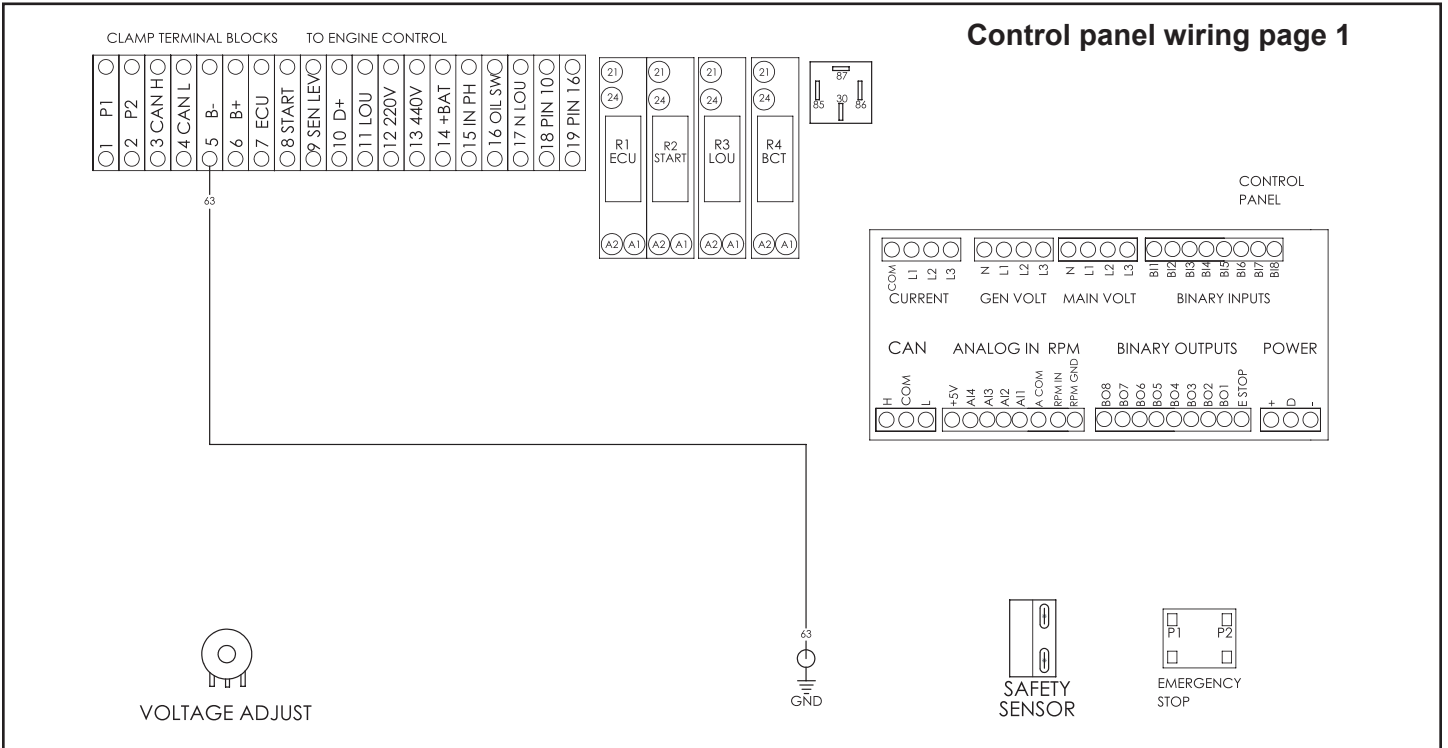

## Control panel wiring page 2

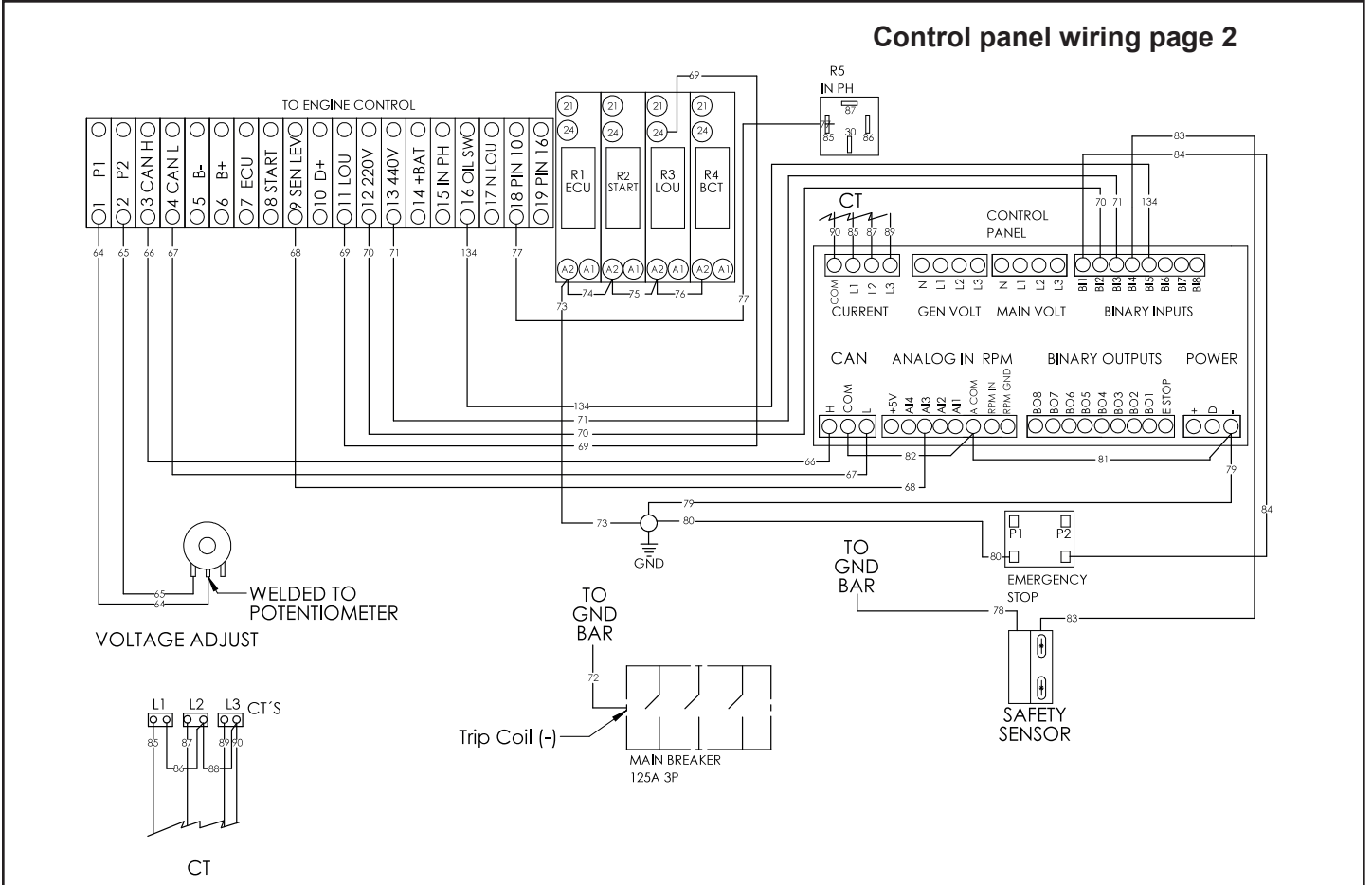

### Control panel wiring page 3

TO ENGINE CONTROL

○1	P1	○
○2	P2	○
○3	CAN HO	○
○4	CAN L	○
○5	B-	○
○6	B+	○
○7	ECU	○
○8	START	○
○9	SEN LEVO	○
○10	D+	○
○11	LOU	○
○12	220V	○
○13	440V	○
○14	+BAT	○
○15	IN PH	○
○16	OIL SW	○
○17	N LOU	○
○18	PIN 10	○
○19	PIN 16	○

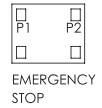
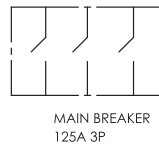
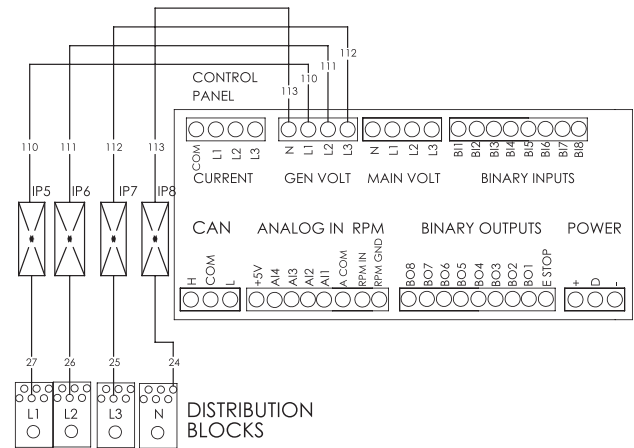

### Control panel wiring page 4

TO ENGINE CONTROL

○1	P1	○
○2	P2	○
○3	CAN HO	○
○4	CAN L	○
○5	B-	○
○6	B+	○
○7	ECU	○
○8	START	○
○9	SEN LEVO	○
○10	D+	○
○11	LOU	○
○12	220V	○
○13	440V	○
○14	+BAT	○
○15	IN PH	○
○16	OIL SW	○
○17	N LOU	○
○18	PIN 10	○
○19	PIN 16	○

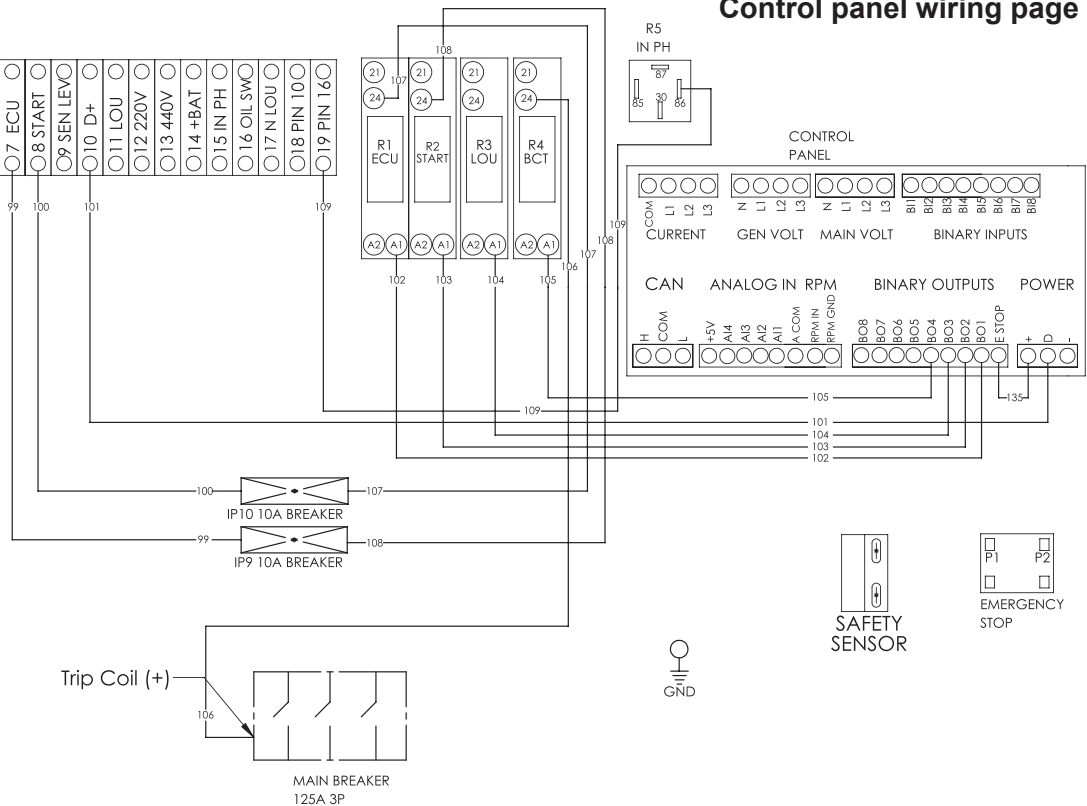

Trip Coil (+)





## Control panel wiring page 5

CLAMP TERMINAL BLOCKS TO ENGINE CONTROL

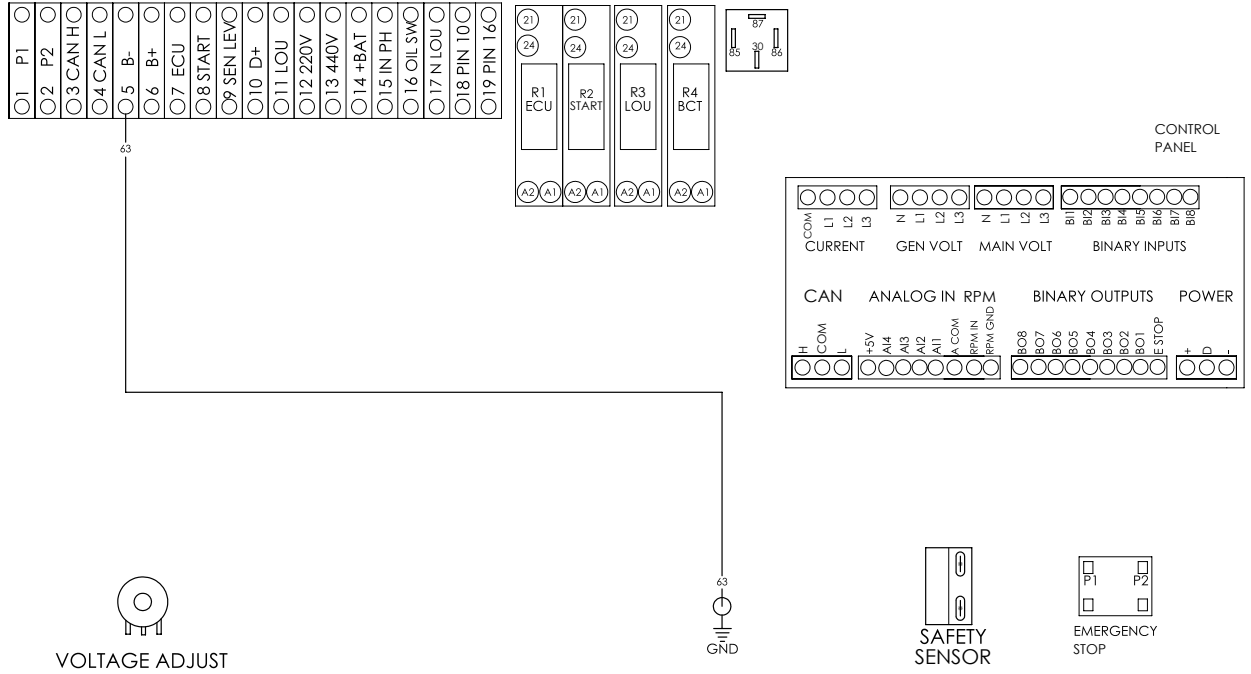

## Control panel wiring page 6

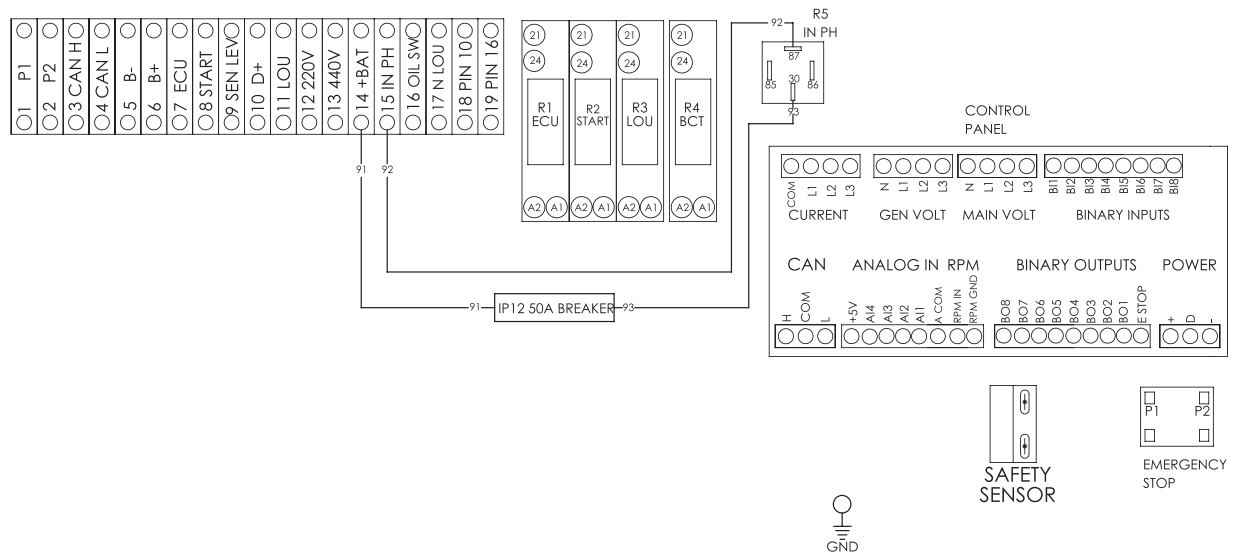

# Power wiring

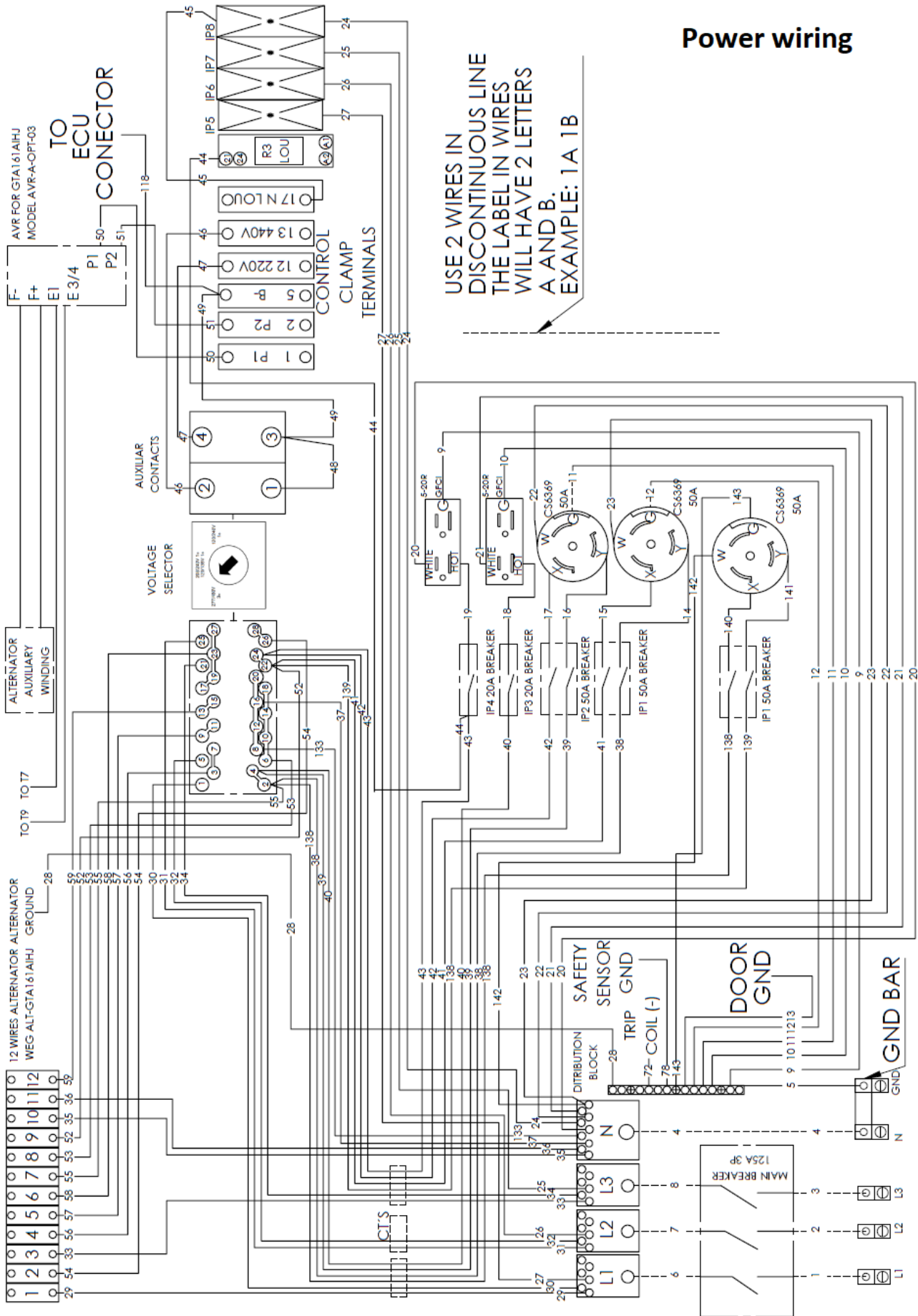

USE 2 WIRES IN DISCONTINUOUS LINE THE LABEL IN WIRES WILL HAVE 2 LETTERS A AND B. EXAMPLE: 1A 1B

AVR FOR GTA161AHJ  
MODEL AVR-A-OPT-03  
TO ECU  
CONECTOR

F-  
F+  
E1  
E3/4  
P1  
P2

ALTERNATOR  
- AUXILIARY  
- WINDING

12 WIRES ALTERNATOR  
WEG ALT-GTA161AHJ

29 54 33 56 57 38 55 53 52 35 36 52  
1 2 3 4 5 6 7 8 9 10 11 12  
0 0 0 0 0 0 0 0 0 0 0 0 0 0 0 0 0

AUXILIAR CONTACTS  
46 47 48 49  
2 4 3 1

VOLTAGE SELECTOR  
277-200V  
300V  
311-200V

TO 19 TO 17  
TO 19 TO 17

CONTROL CLAMP TERMINALS  
50 51 49 47 46 45 44 45 27 26 25 24

17N LOU  
13 440V  
12 220V  
5 P  
2 P2  
1 P1

R3 LOU  
3 3

IP5 IP6 IP7 IP8

5-20R  
WHITE  
HOT  
GFCCI 9

5-20R  
WHITE  
HOT  
GFCCI 10

CS6369  
50A  
1-11

CS6369  
50A  
1-12

CS6369  
50A  
1-14

CS6369  
50A  
1-43

CS6369  
50A  
1-41

IP4 20A BREAKER  
43 44 40

IP3 20A BREAKER  
42 39 41

IP2 50A BREAKER  
38 37 36 35 34 33 32 31 30 29

IP1 50A BREAKER  
14 42 138 139 140 141

SAFETY SENSOR  
DISTRIBUTION BLOCK  
TRIP COIL (-)  
72-78

DOOR GND  
5 9 10 11 12 13

GND BAR  
GND 20

MAIN BREAKER  
125A 3P  
1 2 3 4 6 7 8

L1 L2 L3  
1 2 3

N

# Engine control wiring

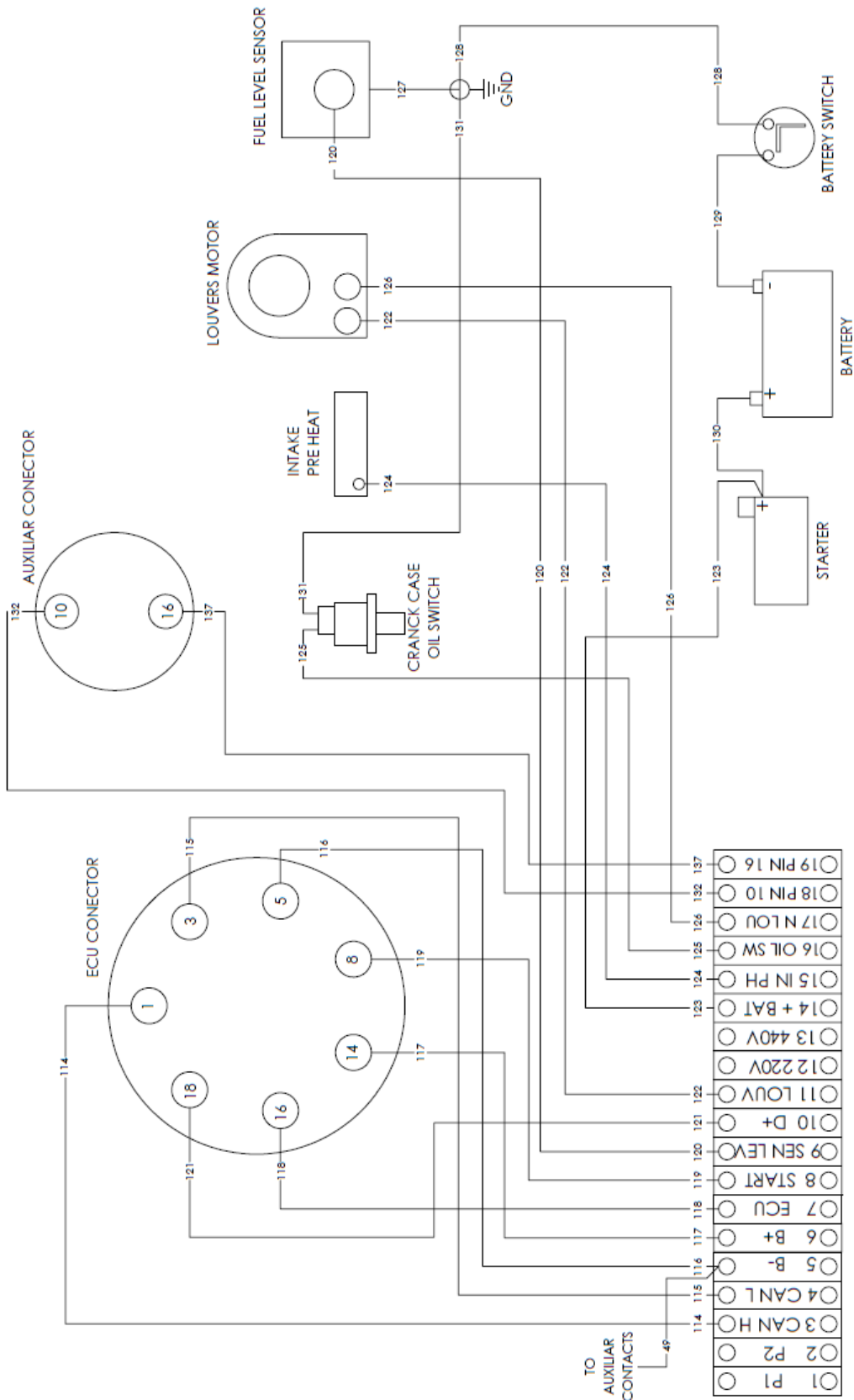







# **megagen**

**Phone: 844 732 9466**

**service@axiomequipmentgroup.com**